

PURGE SOLUTIONS®

CYCLOPS

Z – Purge Indicator



IOM Manual

This page intentionally left blank

Information in this document is subject to change without notice. All terms mentioned in this manual that are known to be trademarks have been appropriately capitalized. Purge Solutions, Inc. acknowledges all trademark(s) and the rights of the trademark(s) owned by the company referred to herein.



592 Avenue E 1/2, Alvin, Texas 77511 USA

Phone: 832-368-7166

Fax: 281-824-4418

E-mail: info@purgesolutions.com

Web site: <http://www.purgesolutions.com>

Release Date: 12-August-2002
 Document Number: DO-10011-Y
 © Copyright 2002 by Purge Solutions, Inc.
 All rights reserved

Revision Record		
Rev.	Description	Date
A	Initial Release	12-Aug-02
B	Web Site Changes	02-Jan-03
C	Add 12 DC Powered Model	23-Mar-03
D	Several Revisions	07-Dec-03
E	Several Revisions	14-Mar-04
F	Several Revisions	29-June-04
G	Several Revisions	14-Dec-04
H	Several Revisions	27-May-05
I	Added Recommended UL Power Supply Requirements	06-Jan-06
J	Revised Options and Illustrations	01-Mar-06
K	Revised Initial and Maintenance Start Up Procedures	13-Jan-07
L	Revised Illustrations	24-Jan-08
M	Revisions Per Certification Updates and New Product Offerings	23-Aug-08
N	Revisions Per New Purge Gas Inlet Kits Procedures	21-Aug-09
O	Several Revisions	11-Nov-09
P	Addition of Dust and Amended Installation Instructions	18-Nov-10
Q	Removal of CYCLOPS Y – Purge Indicator from this manual	13-Jun-11
R	Addition of Increase Safety Window Kits and UL Certification	17-Jun-13
S	Address and Certification Changes	25-Nov-13
T	Certification Required Revisions	18-Sep-14
U	Added Storage Temperature Range	21-May-15
V	Change of Address	27-May-16
W	Several Revisions	23-Mar-18
X	Several Updates	25-Nov-19
Y	Added UKEx Certification	12-May-2021

Copyright Notice:

This document contains information proprietary to Purge Solutions, Inc. with all rights reserved worldwide. Any reproduction or disclosure of this publication, or any part thereof, to persons other than Purge Solutions, Inc. personnel or customers is strictly prohibited, except by written permission of Purge Solutions, Inc. Unauthorized use, disclosure, reproduction, or translation of this publication will result in Purge Solutions, Inc. exercising maximum possible legal action against all persons and/or organizations involved.

Disclaimer:

Purge Solutions, Inc. makes every effort to ensure the accuracy and completeness of this manual. However, we cannot be responsible for errors, omissions, or any loss of data as the results of errors or omissions. We therefore make no representations or warranties with respect to the contents hereof. Further, Purge Solutions, Inc. reserves the right to revise this publication and to make changes in the content hereof, without obligation to notify any person or organization of such revision or changes.

Shipment Arrival Procedures:

This shipment has been thoroughly inspected at the factory prior to its delivery to the carrier. After the shipment is picked up by the carrier, it becomes their responsibility. When the shipment arrives, make certain that it is undamaged and complete.

Patent Notice:

Manufactured under United States, Worldwide Patents, and Patents Pending.

Trademark Information:

Purge Solutions, Inc. and its logo(s) are trademark(s) of Purge Solutions, Inc.

Table of Contents

Legal Notices and Revision History Inside
front cover

Section 1

How To Use This Manual	1
Safety Considerations	1
Label Definition Table	2
Locating Information	2
General Safety	2
General Precautions	3
Electrical Power	4
System Location	4
Conditions of Safe Use	5

Section 2

Specifications	6
Features Table	6
Normal Operating Conditions Table	6
Utility Requirements Table	7
Environmental Conditions Table	7
Model Number Matrix	8

Section 3

Introduction	9
Description	9
Warranty	12

Section 4

Installation	13
Indicator Installation Procedure	13
Protective Gas Inlet Kit Installation Procedure	24
Back-Up Exhaust Vent Installation Procedure	31

Section 5

Start Up Procedures	38
Continuous Dilution Explosive Gas Applications	39
Continuous Dilution Combustible Dust Applications	42
Leakage Compensation Explosive Gas Applications	44

Section 6

Maintenance Procedures	48
Continuous Dilution Explosive Gas Applications	48
Continuous Dilution Combustible Dust Applications	50
Leakage Compensation Explosive Gas Applications	52

Section 7

Options	55
---------	----

Section 8

Getting Help	57
--------------	----

Section 1

How to Use This IOM Manual

Safety Considerations:

This chapter includes important information that must be read and understood by all persons installing, using, or maintaining this equipment. While this IOM Manual is designed to aid personnel in the correct and safe installation, operation, and maintenance of the systems described. Personnel must consider all actions and procedures for potential hazards or conditions that may not have been anticipated in the written procedures. If a procedure cannot be performed safely, it must not be performed until appropriate actions can be taken to ensure the safety of personnel and equipment. The procedures in this IOM Manual are not designed to replace or supersede required or common sense safety practices. All safety warnings listed in any documents applicable to equipment and parts used in or with the system described in this IOM Manual must be read and heeded before commencing work on any part of the system.



NOTE: Refer to all ATEX, CEC, IECEX, NEC, NFPA and UKEx certificates for any Special Conditions of Use. If the sign “X” is placed after the certificate number, it indicates that the equipment or protective system is subject to special conditions for safe use specified in the schedule of the certificate.



NOTE: Review all material and safety information in this IOM Manual and install in accordance with this document and all other applicable ATEX, CEC, IECEX, NEC, NFPA and UKEx standards.





WARNING: Failure to follow appropriate safety procedures or inappropriate use of the equipment described in this manual can lead to injury of personnel or equipment damage.



WARNING – EXPLOSION HAZARD – Do not disconnect equipment unless power has been removed or the area is known to be non-hazardous.

The following symbols are used throughout this IOM Manual to alert users to potential hazards or important information. ***Failure to heed the warnings and cautions listed herein can lead to injury and equipment damage.***

Document Label Definitions Used to Indicate Potential Hazards		
Symbol	Label	Description
	WARNING:	Consists of conditions, practices or procedures that must be observed to prevent personal injury and / or equipment damage.
	CAUTION:	Risk of electric shock or high temperature parts may result in injury if proper precautions are not taken.
	NOTE:	Emphasizes important or essential information.

Locating Information:



NOTE: *In the interest of completeness, manuals and drawings included with the system may provide information pertaining to options not included with your equipment. Information in application notes supersedes general information in these documents. Information can be located in this manual using any of the following aids.*

1. Table of Contents
2. Getting Help

General Safety and Operating Information:

This section contains general safety and operating information applicable to electrical equipment installed within hazardous locations. This information must be understood by all persons installing, using, or maintaining the electrical equipment. This information is designed to aid personnel in safe installation, operation, and maintenance of the Type Z – Purge System. It is not designed to replace or limit appropriate safety measures applicable to work performed by personnel. Any additional safety and operating measures that are required must be determined by and followed by personnel performing work on the electrical equipment.



WARNING: Deviation from the specified instruction or procedure steps can result in injury to personnel, equipment malfunction and / or equipment damage.



WARNING: Return unit to factory for any repairs or replacement of parts, customer not permitted. This will void all warranties and hazardous area certification(s).

General Precautions:

Protective eyewear (*glasses with side shields or goggles as appropriate*) must be worn when servicing any part of electrical equipment. Hot components should be allowed to cool before servicing if possible. Other appropriate equipment or clothing must be used as required by the type of work performed. All applicable regulations and procedures must be followed for the work performed. **Before** beginning any work on the equipment, carefully consider all the potential hazards and ensure that appropriate measures are taken to prevent injury to personnel or equipment damage.



CAUTION: Applicable permits must be obtained and appropriate precautions must be taken to prevent possible injury to personnel or equipment damage when installing or maintaining this equipment.

Enclosure shall be marked by the end user identifying enclosure as pressurized. The pressurized enclosure shall be marked the following or similar.



WARNING: PRESSURIZED ENCLOSURE.

To prevent the ignition of an explosive gas atmosphere or a combustible dust atmosphere, which may be present when an enclosure is opened, doors and covers shall be marked the following or similar.



WARNING: DO NOT OPEN WHEN AN EXPLOSIVE ATMOSPHERE IS PRESENT.

Instructions shall be marked on the equipment by the end user to ensure proper purging the pressurized enclosure before energizing the electrical equipment. The instructions shall include the following or similar.



WARNING: POWER SHALL NOT BE RESTORED AFTER ENCLOSURE HAS BEEN OPENED UNTIL ENCLOSURE HAS BEEN PURGED FOR ___ MINUTES AT A MINIMUM FLOW RATE OF ___.

For applications located in a Combustible Dust Atmosphere; a warning shall be marked on the equipment stating that combustible dust shall be removed from the interior prior to switching on the electrical supply. The marking shall include the following or similar:



WARNING: POWER SHALL NOT BE RESTORED AFTER THE ENCLOSURE HAS BEEN OPENED UNTIL COMBUSTIBLE DUST ACCUMULATIONS WITHIN THE ENCLOSURE HAVE BEEN REMOVED.

Electrical equipment mounted inside pressurized enclosure may have hot surfaces that exceed the ignition temperature of the flammable or combustible substance located in the hazardous location; even when power has been removed. Take appropriate precautions to prevent injury from contact with hot items or damage to equipment and to allow for adequate cooling; the equipment shall be marked with instructions that include the following or similar.



WARNING: DO NOT OPEN ENCLOSURE DOOR OR COVER FOR _____ MINUTES AFTER REMOVING POWER.

Electrical Power:

The CYCLOPS Z – Purge Indicator uses AC power of 115 or 230 volts and DC power of 12 or 24. The AC power is converted to DC. Appropriate precautions must be taken to prevent sparks that may ignite combustible materials that may be present in the Purge Indicator's environment. Precautions must also be taken to prevent electrical shock if the electrical equipment's enclosure being monitored by the CYCLOPS Z – Purge Indicator is opened. The power to the CYCLOPS Z – Purge Indicator must be free from noise, surges, sags, and spikes for proper operation of the purge indicator. AC power circuit breakers and wiring must be sized properly for the required current. All wiring installations must meet applicable electrical codes.



WARNING: Do not connect or disconnect CYCLOPS Z – Purge Indicator when energized.

System Location:

The CYCLOPS Z – Purge Indicator must not be installed in an area classification for which it is not rated and must be protected from temperature extremes and potentially high vibration. The CYCLOPS Z – Purge Indicator must be attached securely and appropriately to the wall of the electrical equipment's enclosure being monitored per the mounting instructions page 13 and mounted in a location to permit adequate viewing of green indicator light and to permit proper purge exhaust venting.

Purge & Pressurization System Conditions of Safe Use:



CAUTION: *The safe handling and operation of a purge and pressurization system requires basic knowledge of safety standards with additional training and experience to work on explosion protection equipment.*



CAUTION: *Applicable permits must be obtained and appropriate precautions must be taken to prevent possible injury to personnel or equipment damage when installing or maintaining this equipment.*



WARNING: *Enclosures being monitored by a type Z – Purge System must not be opened unless power is disconnected from the electrical equipment within enclosure or the area is known not to contain explosive or combustible materials.*



CAUTION: *This purge unit has an operating temperature of 85°C or T6 temperature class. This operating temperature shall be considered when mounted to the enclosure it will be monitoring.*



NOTE: *This equipment is suitable for use in Class I, Division 2, Group A, B, C & D, Class II, Division 2, Group F & G, Class III Hazardous Location or unclassified locations.*



NOTE: *This device is a Purge and Pressurization Type Z – Purge System intended to be mounted to an enclosure that would need final assembly to be fully evaluated to NFPA 496. For correct evaluation, installation and assembly guidance refer to NFPA 496, 2017 Edition.*



NOTE: *This equipment is suitable for use in Zone 2, IIC or Zone 22, IIIC Hazardous Location or unclassified locations.*



NOTE: *This device is a Purge and Pressurization Type Z – Purge System intended to be mounted to an enclosure that would need final assembly to be fully evaluated to IEC 60079-2. For correct evaluation, installation and assembly guidance refer to IEC 60079-2:2014 Edition.*



NOTE: *Purging of pressurized equipment is not suitable for Combustible Dust Hazardous Locations since purging is likely to cause a dust cloud from purge gas exiting exhaust vent.*



WARNING: *For combustible dust applications power shall not be restored after the enclosure has been opened; until combustible dust accumulations within the enclosure have been removed.*



WARNING: *Substitution of components may impair suitability for Division 2.*

Section 2

Specifications

Features and Certifications	
Certified for installation and use in ATEX, IECEx, UKEx and CE Marked II 3G Ex ec ic [pzc] IIC T6 Gc $-40^{\circ}\text{C} \leq \text{Ta} \leq +65^{\circ}\text{C}$, Zone 2 gas hazardous areas II 3D Ex ic [pzc] tc IIIC T79°C Dc IP66 $-40^{\circ}\text{C} \leq \text{Ta} \leq +65^{\circ}\text{C}$, Zone 22 dust hazardous areas ATEX Certificate Number = ExVeritas 19ATEX0446X IECEx Certificate Number = IECEx EXV 19.0006X UKEx Certification Number = ExVeritas 21UKEX0901X Standards = IEC / EN60079-0, IEC / EN60079-2, IEC / EN 60079-7, IEC / EN 60079-11 and IEC / EN 60079-31	
Certified for installation and use to CEC, NEC and NFPA for Class I, Division 2, Group A, B, C & D, T6, gas hazardous areas Class II, Division 2, Group F & G, T6, dust hazardous areas	

Normal Operating Conditions	
Minimum Purge Cycle Time Before Electrical Equipment May Safely be Energized	Typically , purge cycle time is to ensure that at least four (4) times for Division and five (5) times for Zone; the volume of free space in the enclosure of protective gas supply is exchanged before power is connected to the pressurized protected electrical equipment. Ten (10) times volumes for motors, generators and other rotating electrical machinery. The number of exchanged volumes may be higher in some situations.
Enclosure Minimum Overpressure	Green indicator light remains on to show minimum overpressure being maintained above 0.30 inch H ₂ O (0.75 mbar) for explosive gas atmospheres or 0.50 inch H ₂ O (1.25 mbar) for combustible dust atmospheres, in electronics enclosure being monitored. To help avoid Purge Indicator pressure switch damage; maximum protective gas overpressure inside enclosure should never be more than 4 psig (0.27 bar).
Indicator Mounting Orientation	Can be mounted vertical on door, left or right side of enclosure; provided there is ease of viewing LED indication and adequate exhaust venting of enclosure.
Protective Gas Inlet Kit Mounting Orientation	Can be mounted on top, bottom, left or right side of enclosure with no restrictions; provided there is ease of interface to pressure regulator for required pressure / flow adjustment. Pressure gauge can be mounted on either side of the pressure regulator.
Back-Up Vent Mounting Orientation	Can be mounted vertical on top, left or right side of enclosure; provided there is adequate venting of enclosure. Cracking / opening pressure is between 0.8 to 1.0 inch H ₂ O (2.0 to 2.5 mbar).

Utility Requirements	
Minimum Protective Gas Supply Pressure to Protective Gas Inlet Kit Pressure Regulator	20 psig (1.4 bar) (<i>Suggested to compensate for enclosure leak rate</i>)
Maximum Protective Gas Supply Pressure to Protective Gas Inlet Kit Pressure Regulator	150 psig (10.3 bar) (<i>Certification maximum pressure rating.</i>)
Protective Gas Supply Quality	Water and oil-free, - 40°F (- 40°C) dew point, particles ≤ 5μ, ISA grade hydrocarbon free
CYCLOPS Z – Purge Indicator Power Input / Consumption	0.5 Watts maximum
Supply Voltage to CYCLOPS Z – Purge Indicator	12 Volt model: 12 VDC, polarity protected 24 Volt model: 24 VDC, polarity protected 115 Volt model: 115 VAC, 50 / 60 Hz 230 Volt model: 230 VAC, 50 / 60 Hz
CYCLOPS Z – Purge Indicator Alarm Maximum Continuous Load Contact Rating	150 mA rms AC 150 mA DC
Mains Supply Fluctuation	Not to Exceed 10%

Environmental and Material Specifications	
Operating Temperature Range	- 40°F to 150°F (- 40°C to 65°C)
Storage Temperature Range	- 58°F to 167°F (- 50°C to 75°C)
CYCLOPS Z – Purge Indicator, Aluminum Weight	2.5 lbs. (1.2 kg)
CYCLOPS Z – Purge Indicator, Stainless Steel Weight	6.7 lbs. (3.1 kg)
Continuous Dilution, Small, Purge Gas Inlet Kit, Aluminum	2.0 lbs. (0.9 kg)
Continuous Dilution, Small, Purge Gas Inlet Kit, Stainless	2.8 lbs. (1.3 kg)
Continuous Dilution, Medium & Large, Purge Gas Inlet Kit, Aluminum	3.0 lbs. (1.4 kg)
Continuous Dilution, Medium & Large, Purge Gas Inlet Kit, Stainless	4.2 lbs. (1.9 kg)
Leakage Compensation, Small, Purge Gas Inlet Kit, Aluminum	4.0 lbs. (1.8 kg)
Leakage Compensation, Small, Purge Gas Inlet Kit, Stainless	5.5 lbs. (2.5 kg)
Leakage Compensation, Medium & Large, Purge Gas Inlet Kit, Aluminum	4.8 lbs. (2.2 kg)
Leakage Compensation, Medium & Large, Purge Gas Inlet Kit, Stainless	6.9 lbs. (3.1 kg)
Small, Side or Top Mount, Back-Up Exhaust Vent, Aluminum	1.3 lbs. (0.6 kg)
Small, Side or Top Mount, Back-Up Exhaust Vent, Stainless	2.4 lbs. (1.1 kg)
Medium, Side or Top Mount, Back-Up Exhaust Vent, Aluminum	2.3 lbs. (1.0 kg)
Medium, Side or Top Mount, Back-Up Exhaust Vent, Stainless	4.0 lbs. (1.8 kg)
Large, Side or Top Mount, Back-Up Exhaust Vent, Aluminum	4.9 lbs. (2.2 kg)
Large, Side or Top Mount, Back-Up Exhaust Vent, Stainless	11.8 lbs. (5.4 kg)

Environmental & Material Specifications, Cont.	
Fittings & Fasteners	Material = Stainless Steel
O-rings	Material = EPDM
Ingress Protection	NEMA 4X (IP66)
Used and Mounted	Monitors One Pressure Point for Indoor and Outdoor Use



NOTE: *CYCLOPS Z – Purge Indicator O-ring shall not exceed 150°F (65°C) ambient temperature when used in for Class II, Division 2 applications.*



WARNING: *Do not overpressure enclosure as this could damage or change factory setting of CYCLOPS Z – Purge Indicator pressure switch. Pressure switch proof pressure is 4 psi (0.27 bar).*

**CYCLOPS Z – Purge Indicator
Model Number Matrix**

PSCZ- 3 S 2

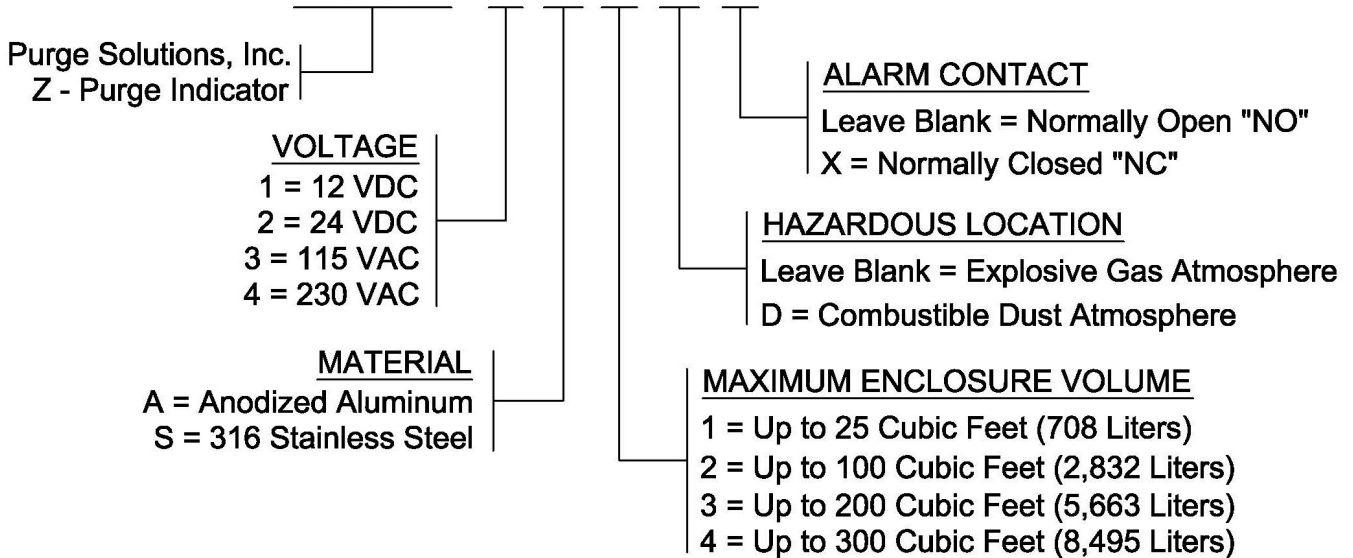

NOTE: *Voltage, Material, Maximum Enclosure Volume, Hazardous Location and Alarm Contact; selections are made by end user to meet final purge and pressurization application requirements (MODEL NUMBER SHOWN ABOVE IS AN EXAMPLE).*

Section 3

Introduction

Description:

Type Z purge / pressurization reduces the classification within a pressurized protected panel from Division 2, Zone 2 or Zone 22 to nonhazardous. Failure to maintain minimum overpressure within the protected enclosure shall be detected and communicated by an indicator and / or alarm. The purge cycle time is a manual operation and once the panel has been purged of explosive concentrations, only a minimum overpressure setting of at least 0.30 inch H₂O (0.75 mbar) for explosive gas atmospheres or 0.5 inch H₂O (1.25 mbar) for combustible dust atmospheres is required to be maintained within the enclosure and it is not necessary to remove power from the protected equipment upon the loss of minimum overpressure within the protected panel.

The CYCLOPS Z – Purge Indicator is used to provide safe monitoring of electrical equipment in Division 2, Zone 2 and Zone 22 hazardous locations, which can be used to prevent the possibility of fire or explosion inside the panel of energized electrical equipment. A protective gas supply is used to purge potentially flammable materials to an acceptable level, creating a safe area for the electrical equipment within the pressurized enclosure. Maintaining a positive pressure prevents the ingress of potentially hazardous materials in the surrounding atmosphere from entering into the enclosure. After the enclosure is purged, power may be manually connected to the electrical equipment within the pressurized protected panel.

The CYCLOPS Z – Purge Indicator provides an objective evidence of the presence of adequate minimum overpressure within the purge and pressurized panel. A differential pressure switch continuously compares the minimum overpressure inside the monitored enclosure with respect to the atmospheric pressure surrounding the enclosure. When the monitored enclosure reaches a minimum overpressure for selected flow rate; purge cycle time will begin. Typically, a minimum purge cycle time is specified to ensure that at least four (4) times for Division and five (5) times for Zone the volume of free space in the enclosure is exchanged before power is manually connected to the electrical equipment inside the pressurized protected enclosure. ***(The number of exchanged volumes may be higher in some situations).***

The CYCLOPS Z – Purge Indicator are designed to indicate the presence of minimum overpressure from one pressure reference point. Several enclosures can be installed in series with protective gas being introduced into the first enclosure and the Z – Purge Indicator monitoring the last enclosure in the series; multiple enclosures can now be monitored using only one Z – Purge System. The minimum overpressure inside the monitored enclosures must maintain at least 0.30 inch H₂O (0.75 mbar) for explosive gas atmospheres or 0.5 inch H₂O (1.25 mbar) for combustible dust atmospheres higher than the atmospheric pressure surrounding the enclosures. This ensures that hazardous materials are not going to ingress into the pressurized and now protected enclosures. If any of the enclosures installed in the series minimum overpressure goes below the required 0.30 inch H₂O (0.75 mbar) for explosive gas atmospheres or 0.5

inch H₂O (1.25 mbar) for combustible dust atmospheres in any pressurized enclosure the CYCLOPS Z – Purge Indicator will alarm. For proper selection of components for your purge and pressurization application, refer to the Purge System Selection Wizard, which can be found on the home page of our web site www.purgesolutions.com.



NOTE: Selection of Protective Gas Inlet Kit and flow rate should be based on available protective gas volume at installation site; not on maximum volume of protective gas that selected Protective Gas Inlet Kit can supply.

The CYCLOPS Z – Purge Indicator uses two different methods to purge the enclosure(s) and maintain a minimum overpressure of at least 0.30 inch H₂O (0.75 mbar) for explosive gas atmospheres or 0.5 inch H₂O (1.25 mbar) for combustible dust atmospheres; continuous dilution or leakage compensation. Continuous dilution is a method of maintaining the same pressure / flow rate during and after the enclosure has been purged below the required lower explosive limit (LEL). The protective gas is passed continuously through the enclosure at a minimum overpressure above that of the required 0.30 inch H₂O (0.75 mbar) for gas hazardous locations or 0.5 inch H₂O (1.25 mbar) for dust hazardous locations and discharged continuously to the outside atmosphere through an exhaust vent. The same volume of protective gas is maintained during and after the purge cycle time. Continuous dilution is normally used to help heat buildup from the electronics within the pressurized panel by continuously exchanging protective gas through the electronics panel to atmosphere. The maximum flow rate that the Continuous Dilution Purge Gas Inlet Kit can supply is 80 SCFM (2,265 LM). Continuous Dilution Protective Gas Inlet Kits are available in materials of anodized aluminum or 316 stainless steel.

The second purge method offered by Purge Solutions, Inc. is leakage compensation, which allows a higher volume of protective gas supply to be manually selected to speed up the purge cycle time, permitting a more-rapid application of initial power or restoration of power to protected electrical equipment, after service. When the purge cycle has elapsed, the larger volume of purge gas can be manually turned off. A volume of purge gas larger than the leak rate of the enclosure will be introduced into the now protected enclosure to maintain a minimum overpressure of at least 0.30 inch H₂O (0.75 mbar) for gas hazardous locations or 0.5 inch H₂O (1.25 mbar) for dust hazardous locations. Leakage compensation is normally used to conserve protective gas when utilities are at a premium. The maximum flow rate that the Leakage Compensation Purge Gas Inlet Kit can supply is 80 CFM (2,265 LM). Both Leakage Compensation Protective Gas Inlet Kits are available in materials of anodized aluminum or 316 stainless steel.



WARNING: Failure to heed the information in this manual may lead to injury of personnel or equipment damage.



CAUTION: Electrical equipment components may be hot even when power is not connected. Take appropriate precautions to prevent injury from contact with hot items.



WARNING: Failure to allow adequate cooling of electrical equipment components with hot surfaces before opening the pressurized enclosure can lead to injury of personnel or equipment damage.

For applications where thermal management of electrical cabinets and control panels are required; Purge Solutions, Inc. offers Vortex Cabinet Cooler Systems, which provide cooling capacities for your application and maintain a NEMA 4X (IP66) rating for installation and use in hazardous locations. Contact your local Purge Solutions, Inc. representative or the factory for sizing of system and installation information.



NOTE: There are special modifications and sizing requirements to be made before Vortex Cabinet Coolers are able to be installed and used in a hazardous location.



NOTE: In the interest of completeness, included in this manual with the Z – Purge System information; additional information pertaining to options not included with your equipment.

Purge Solutions, Inc. also offers ATEX, IECEx, NEMA and UKEx increased safety enclosures in several standard enclosure sizes or we can custom built to the customer specifications, including all holes and cutouts for cable glands, widows, purge systems and any other component can be incorporated into fabrication. As long as the design stays within our conditions of certification no additional assessment and testing is required to maintain ATEX, IECEx, NEMA and UKEx certification.

Our proprietary hinge design allows clamping of door on all four sides for maximum ingress protection with incorporated fasteners that allows door to be removed as needed. Enclosures can be fabricated from 304 or 316 stainless steel, powder coated carbon steel or aluminum with all seams continuously welded and ground before finish is applied. Contact your local Purge Solutions, Inc. representative or the factory for sizing of system and installation information.

For purged and pressurized or increased safety enclosures that require viewing of components mounted within the enclosure; Purge Solutions, Inc. offers both opening and non-opening Increased Safety Window Kits in several standard window viewing sizes, which can be mounted on the door, sides, top or bottom of an enclosure.

If there is not a viewing opening listed in our standard sizes that meets your application requirements; Purge Solutions, Inc. can custom build an opening or non-opening Increased Safety Window Kit for you. As long as the design stays within our conditions of certification no additional assessment and testing is required to maintain ATEX, IECEx, NEMA and UKEx certification. Contact Purge Solutions, Inc. to discuss viewing opening needs.

Purge Solutions, Inc. Standard Terms and Conditions of Sale

The product, equipment, software, material and / or services (collectively the "Product"), which are described in our quotation, purchase order acknowledgment, packing list and / or invoice hereof shall be sold by Purge Solutions, Inc. only upon the following Standard Terms and Conditions of Sale:

1. **CONTRACT TERMS AND ACCEPTANCE OF PURCHASE ORDER:** These Standard Terms and Conditions of Sale (the "Contract") are the only terms and conditions applicable to the sale of the Products, which are based on qualification and completion of the following: a) Acceptance of any Purchase Order is subject to credit approval by Purge Solutions, Inc. b) Acceptance of completed Purge Solutions, Inc. Customer Information Form. c) Final acceptance of Purchase Order will be Purchase Order Acknowledgment being forwarded to Buyer (*Only until Purchase Order Acknowledgment has been forwarded to Buyer has purchase order been accepted and sent to manufacturing for processing.*)
 2. **QUOTATION PRICES:** Quoted prices are valid for thirty (30) days of quotation date and are exclusive of any applicable taxes, shipping charges and / or any other miscellaneous charges not specified in quote. Prices are subject to change without notice. Any change in quantities, partial release and / or destination may incur a price adjustment.
 3. **PAYMENT TERMS:** Purchase Orders inside the Continental United States; are subject to the approval of Purge Solutions, Inc. Credit Department and unless otherwise agreed in writing, terms of payment are NET thirty (30) days following the date of invoice. Purchase orders outside the continental United States, will be shipped upon receipt of full payment and all costing in US dollars. When the purchase order has been acknowledged, an invoice will be provided. When full payment has been received, including shipping and handling charges, purchase order will be shipped. Purge Solutions, Inc. accepts Visa, MasterCard, Discover and American Express as well as banking transfers. Banking transfer fees are not shared and if banking transfer fees are incorrect; purchase orders will not be shipped. If any Buyer fails to comply with these terms and conditions or sale or if Buyer's credit becomes unsatisfactory to Purge Solutions, Inc., Purge Solutions, Inc. reserves the right to terminate the purchase order without liability to Purge Solutions, Inc. and all future purchase orders of Buyer will be COD or credit card terms before shipping. If a company has an outstanding invoice that is five (5) days past the due date, open purchase orders are subject to being held until such time as the past due status has been brought current.
 4. **DELIVERY DATES:** Quoted delivery dates are approximate estimates determined at the time of quotation and are subject to revisions due to variations in order processing and new purchase orders in manufacturing queue since quoting. Purge Solutions, Inc. assumes no liability for losses arising from inaccurate lead time estimates and is able to make partial shipments against this Contract. The Buyer shall not hold Purge Solutions, Inc. responsible for any delay or damages suffered by the Buyer by reason of any delay due to fires, strikes, riots, Acts of God, priorities, Government orders or restrictions, delays by suppliers or materials or parts, inability to obtain suitable and sufficient labor and / or any other unavoidable contingencies beyond the control of Purge Solutions, Inc. In no case shall Purge Solutions, Inc. be liable for any consequential or special damages arising from any delay in delivery. In the event of such delay, the shipping date shall be extended for a period equal to the time lost by reason of such delay.
 5. **CANCELLATIONS:** Only prior to shipping of Product may Buyer terminate purchase order providing the following: a) Purge Solutions, Inc. is given reasonable notice. b) Purge Solutions, Inc. is compensated for all costs, expenses incurred or committed and for any losses resulting. Once a purchase order has been shipped, all sales are final.
 6. **CLAIMS, DAMAGE OR LOSS IN TRANSIT:** Delivery of Product to carrier from Purge Solutions, Inc. facility or other shipping point shall constitute delivery. Buyer shall bear the risk of loss for damage to or loss of Product from the time Purge Solutions, Inc. delivers Product to carrier, Buyer or Buyer agent. Any claims for damage or loss, which has passed to the Buyer shall be filed with the carrier. Buyer shall give written notice to Purge Solutions, Inc. of any claim for shortage or error in Product shipped within five (5) days of receipt of Product.
 7. **WARRENTY AND LIMITATION OF LIABILITY:** Purge Solutions, Inc. Products are warranted free from defects in material and workmanship at the time of shipment for one year thereafter (One year from date of shipping). Any claimed defects with Purge Solutions, Inc. Products must be reported within the warranty period and warranty subject to inspection by Purge Solutions, Inc. All warranty inspections are to be performed at Purge Solutions, Inc. facility. Buyer shall ship with shipping charges paid by the Buyer to Purge Solutions, Inc. facility. After inspection by Purge Solutions, Inc. a quotation of proposed work required will be sent to the Buyer. Purge Solutions, Inc. shall be liable only to replace or repair, at its option, free of charge, Products which are found by Purge Solutions, Inc. to be defective in material or workmanship, and which are reported to Purge Solutions, Inc. within the warranty period as provide previously. This right of replacement shall be Buyer's exclusive remedy against Purge Solutions, Inc. Shipment of repaired or replaced products from Purge Solutions, Inc. facility shall be ex-works or FOB Purge Solutions, Inc. facility. Purge Solutions, Inc. shall not be liable for labor charges or other losses or damages of any kind or description, including but not limited to, incidental, special or consequential damages caused by defective Products. This warranty shall be void if product specifications provided by Purge Solutions, Inc. are not followed concerning methods of installation, operation, usage, storage or exposure to harsh conditions (including, but not limited to, temperature and humidity levels outside the approved ranges). Products furnished by Purge Solutions, Inc. by other suppliers shall carry no warranty except that supplier's warranties as to materials and workmanship. Purge Solutions, Inc. disclaims all warranties, expressed or implied, with respect to such Products. The express warranties set forth herein constitute the only warranties with respect to the products sold in connection herewith. Purge Solutions, Inc. makes no representation or warranty of any kind, express or implied (either in fact or by operation of law), with respect to the Products, whether as to their merchantability, fitness for a particular purpose or otherwise. No employee, agent or representative of Purge Solutions, Inc. has any authority to bind Purge Solutions, Inc. to any oral or written representation or warranty concerning the Products over and above that stated herein, except by written amendment signed by Purge Solutions, Inc. and Buyer.
 8. **RETURNS:** Subject to the terms of this Contract regarding CANCELLATION and WARRANTY, All sales are final. Buyer may request a warranty return by contacting Purge Solutions, Inc. and requesting a Return Merchandise Authorization Number. No Product will be accepted for return without a valid Return Merchandise Authorization form and clearly noted on the outside of the shipment. Any return shipment must be made by prepaid freight unless Purge Solutions, Inc. has expressly authorized Buyer in writing to ship such Product to Purge Solutions, Inc. at Purge Solutions, Inc. expense. Any returns of Product authorized by Purge Solutions, Inc. under certain circumstances are subject to a standard restocking charge of 25% of the purchase order's invoice. Non-stock Products are subject to higher restocking charges, if return privileges are extended.
 9. **SERVICES:** Services rendered by Purge Solutions, Inc. whether with or without charge, are only advisory in nature and are only merely incidental to the sales of the Product. When any such services are rendered, Buyer will retain full responsibility for and full control, custody and supervision of the Product, its installation, selection thereof and a representative of Buyer shall be present with full authority to direct operations.
-

Section 4

Purge and Pressurization System Installation



WARNING: Before attempting to install the Type Z – Purge System, review all the material and all safety information in this IOM Manual and all other applicable documents.



WARNING: Applicable permits must be obtained and appropriate precautions must be taken to prevent possible injury to personnel or equipment damage when installing the Type Z – Purge System.



NOTE: Refer to all ATEX, CEC, IECEX, NEC, NFPA and UKEx certificates for any Special Conditions of Use. If the sign “X” is placed after the certificate number, it indicates that the equipment or protective system is subject to special conditions for safe use specified in the schedule of the certificate.



NOTE: Review all material and safety information in this manual and install in accordance with this document and all other applicable ATEX, CEC, IECEX, NEC, NFPA 496 and UKEx standards.

Indicator Installation Procedures:

Review all of the material in this IOM Manual prior to installing the CYCLOPS Z – Purge Indicator to the enclosure it will be monitoring. If you have any questions, please contact your local Purge Solutions, Inc. representative or the factory (refer to Getting Help page 57) or view installation video, which can be found on our web site www.purgesolutions.com.

Step 1: Make sure that area surrounding the enclosure to be monitored by the CYCLOPS Z – Purge Indicator is known to be non-hazardous.

Step 2: Make sure that all power is removed from the electrical equipment located in the enclosure where the CYCLOPS Z – Purge Indicator will be installed.

Step 3: Choose a mounting location for the CYCLOPS Z – Purge Indicator on the enclosure in a location farthest from the protective supply gas inlet in order to allow proper enclosure dilution, refer to Installation Flow Diagrams drawing numbers DO-11007-H-1 through 4 with possible mounting location. The chosen location should also permit adequate viewing of the green indicator LED and proper purge exhaust venting.

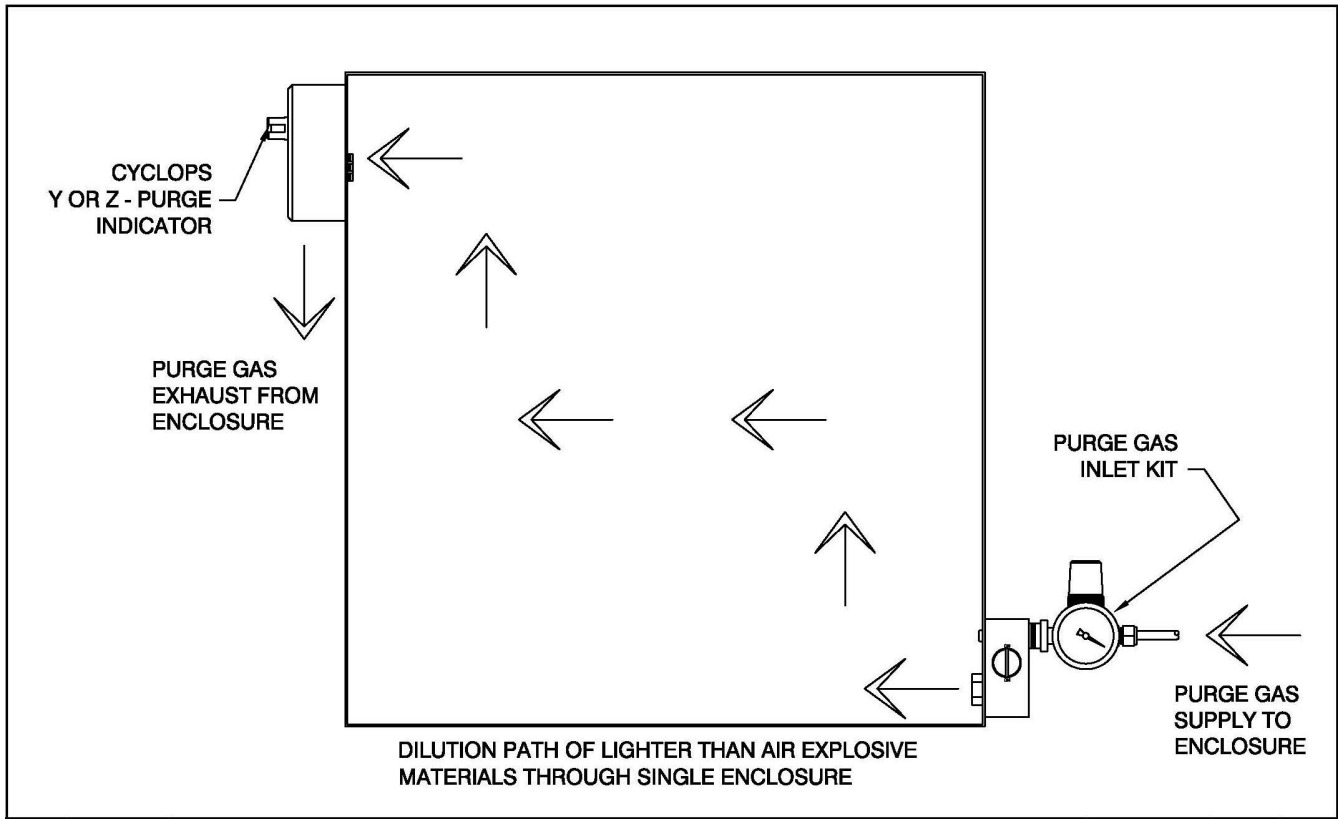

REV #	ECO #	CHANGE(S) DESCRIPTION	DATE	CHANGE BY	APPD BY
<p>The contents of this drawing is the sole property of Purge Solutions. This print and/or its contents shall not be traced or reproduced without prior written permission from Purge Solutions. It shall not be used directly or indirectly in any way detrimental to the interest of Purge Solutions.</p>		<p>DO NOT SCALE DRAWING UNLESS OTHERWISE SPECIFIED: Dimensions Are in Inches Dimensions in 1/16 in mm Tolerances: X = ± 0.015 XX = ± 0.010 XXX = ± 0.005 Angular = ± 0.5° Break All Sharp Edges OS Minimum Except As Noted</p>	<p>DRAWN: WJT DATE: 03/MAY/02</p>	<p>TITLE: FLOW FOR LIGHTER THAN AIR HAZARDOUS MATERIALS CYCLOPS Y OR Z - PURGE INDICATOR, SINGLE ENCLOSURE</p>	
		<p>CHECKED: WJT DATE: 03/MAY/02</p>	<p>PART & DWG #: DO-11007-H-1</p>	<p>MATERIAL: NOTED</p>	
		<p>APPROVED: WJT DATE: 03/MAY/02</p>	<p>SHEET 1 OF 4</p>	<p>SCALE: N/A</p>	<p>DWG SIZE: A</p>
				<p>FINISH: N/A</p>	
			 WEBSTER, TEXAS, USA 832-368-7186		



NOTE: Purge / Pressurization Systems Recommended Connections for Single Enclosure are as follows:

1. Purge / pressurization system should be installed for best ease of viewing any system pressure gauges and / or visual alarms.
2. All tubing, piping and fittings should be selected and used that are suitable for the location they will be installed, used and protected from damage.
3. No valves shall be installed between the purge / pressurization system and enclosure.
4. Always refer to proper ATEX, CEC, IECEx, NEC, NFPA and UKEx standards for proper installation and required tests for certification of any complete purge / pressurization system installed on enclosure.
5. Minimum Protection Gas supply 3/8 inch O.D. tubing or 1/4 inch I.D. pipe with a Maximum of 20 feet length and 10 bends.

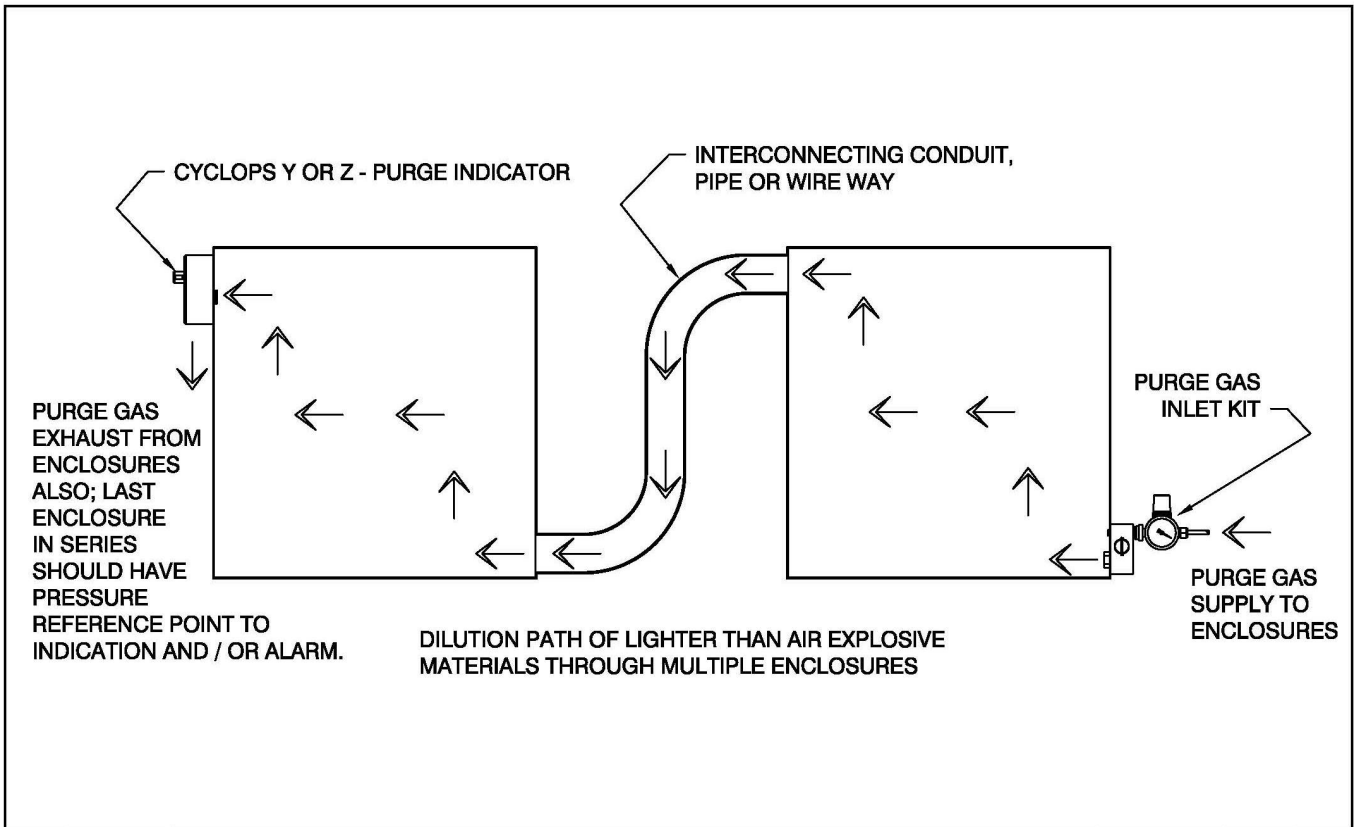

REV #	ECO #	CHANGE(S) DESCRIPTION	DATE	CHANGE BY	APPD BY
<p>The contents of this drawing is the sole property of Purge Solutions. This print and/or its contents shall not be traced or reproduced without prior written permission from Purge Solutions. It shall not be used directly or indirectly in any way detrimental to the interest of Purge Solutions.</p>		<p>DO NOT SCALE DRAWING. UNLESS OTHERWISE SPECIFIED. Dimensions Are in Inches Dimensions in () Are in mm Tolerances: X = ± 0.015 XX = ± 0.010 XXX = ± 0.005 Angular = ± 0.5° Break All Sharp Edges BS Minimum Except As Noted</p>	<p>DRAWN: WJT DATE: 03/MAY/02</p>	<p>TITLE: FLOW FOR LIGHTER THAN AIR HAZARDOUS MATERIALS CYCLOPS Y OR Z - PURGE INDICATOR, MULTIPLE ENCLOSURES</p>	
		<p>CHECKED: WJT DATE: 03/MAY/02</p>	<p>PART & DWG #: DO-11007-H-2</p>	<p>MATERIAL: NOTED</p>	
		<p>APPROVED: WJT DATE: 03/MAY/02</p>	<p>SHEET 2 OF 4</p>	<p>SCALE: N/A</p>	<p>DWG SIZE: A</p>
				<p>FINISH: N/A</p>	
				<p>PURGE SOLUTIONS[®] WEBSTER, TEXAS, USA 832-368-7168</p>	



NOTE: Purge / Pressurization Systems Recommended Connections for Multiple Enclosures will include the recommendations for single enclosure plus the following:

1. Enclosures in series should be connected from smallest to largest enclosure.
2. Connections between enclosures should be properly sized to allow proper operation of purge / pressurization system and proper purge gas flow through enclosures.
3. Conduit and wire ways can be utilized as protected enclosures or as connections between enclosures, as such volumes of conduit or wire ways should be added to overall volume to be diluted before power can be applied.
4. Minimum Protective Gas supply 3/8 inch O.D. tubing or 1/4 inch I.D. pipe with a Maximum of 20 feet length and 10 bends.
5. Minimum Multi-Enclosure connections 1 1/2 inch I.D. pipe of tubing with a Maximum of 12 feet length and 6 bends.

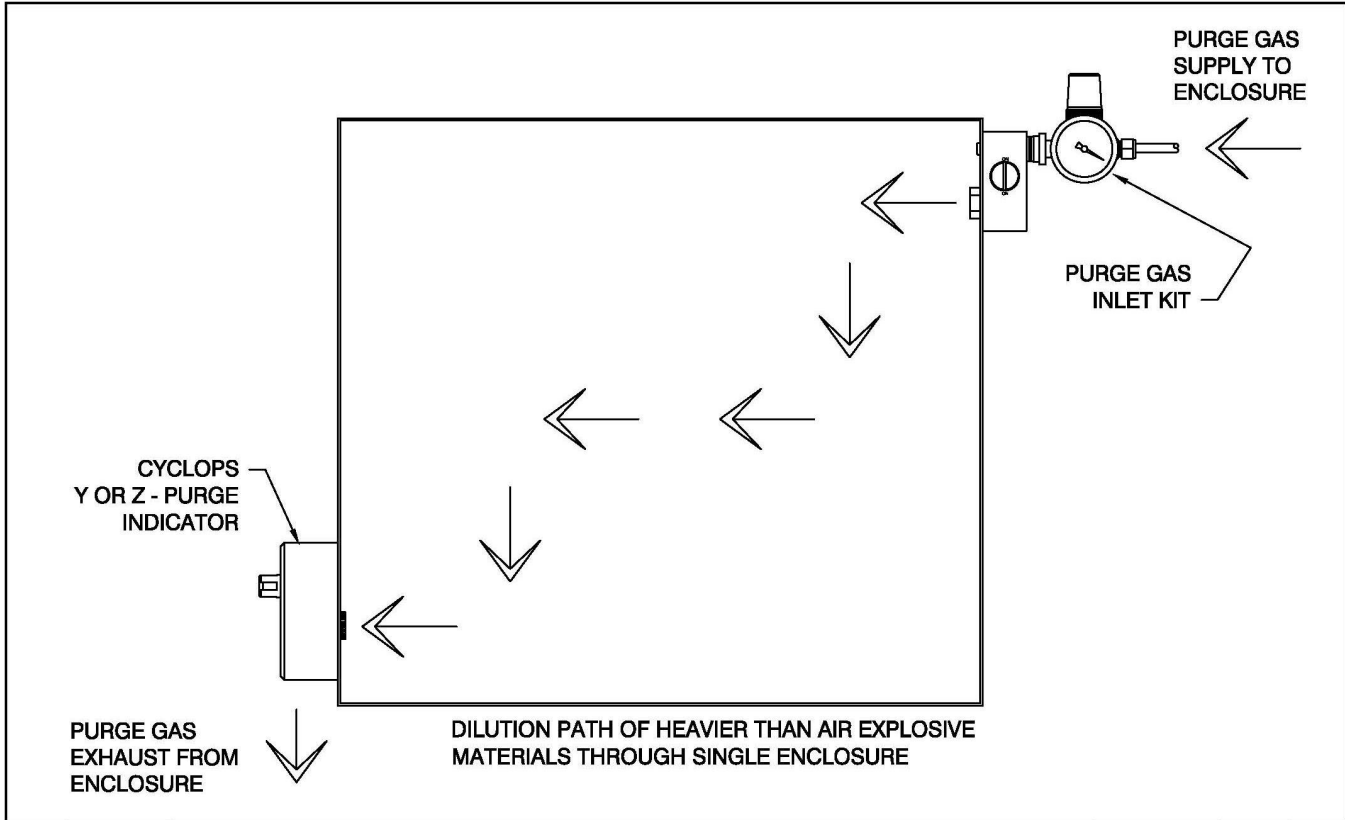

REV #	ECO #	CHANGE(S) DESCRIPTION	DATE	CHANGE BY	APPD BY	
<p>The contents of this drawing is the sole property of Purge Solutions. This print and/or its contents shall not be traced or reproduced without prior written permission from Purge Solutions. It shall not be used directly or indirectly in any way detrimental to the interest of Purge Solutions.</p>		<p>DO NOT SCALE DRAWING UNLESS OTHERWISE SPECIFIED. Dimensions Are In Inches Dimensions In () Are In mm. Tolerances: .X = ± 0.015 .XX = ± 0.010 .XXX = ± 0.005 Angular = ± 0.5° Break All Sharp Edges BS Minimum Except As Noted</p>	<p>DRAWN: WJT DATE: 03/MAY/02</p>	<p>TITLE: FLOW FOR HEAVIER THAN AIR HAZARDOUS MATERIALS CYCLOPS Y OR Z - PURGE INDICATOR, SINGLE ENCLOSURE</p>		
		<p>CHECKED: WJT DATE: 03/MAY/02</p>	<p>PART & DWG #: DO-11007-H-3</p>	<p>MATERIAL: NOTED</p>		
		<p>APPROVED: WJT DATE: 03/MAY/02</p>	<p>SHEET 3 OF 4</p>	<p>SCALE: N/A</p>	<p>DWG SIZE A</p>	
				<p>FINISH: N/A</p>		
				<p>PURGE SOLUTIONS WEBSTER, TEXAS, USA 832-368-7166</p>		



NOTE: Purge / Pressurization Systems Recommended Enclosure Installation for Hazardous Areas with Flammable Gasses or Vapors that are Lighter than Air are as follows:

1. The purge gas inlet supply connection should enter the enclosure near the bottom corner of the enclosure.
2. As such the enclosure exhaust vent should be installed near an extreme opposite top corner of the enclosure.
3. Refer to drawing number DO-11007-H-1 for illustration of lighter than air single enclosure flow diagram.
4. Refer to drawing number DO-11007-H-2 for illustration of lighter than air multiple enclosures flow diagram.
5. Minimum Protective Gas supply 3/8 inch O.D. tubing or 1/4 inch I.D. pipe with a Maximum of 20 feet length and 10 bends.

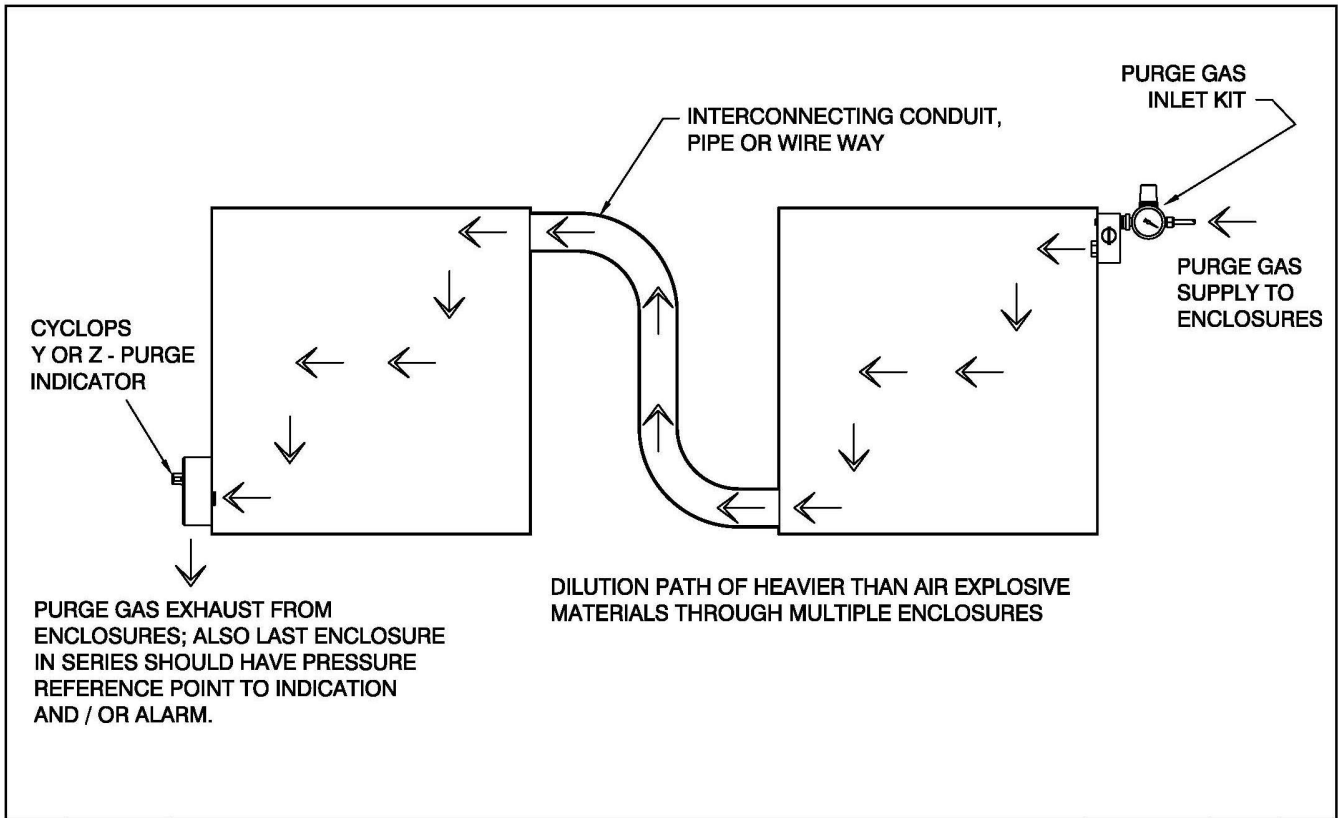

REV #	ECO #	CHANGE(S) DESCRIPTION	DATE	CHANGE BY	APPD BY

<p>The contents of this drawing is the sole property of Purge Solutions. This print and/or its contents shall not be traced or reproduced without prior written permission from Purge Solutions. It shall not be used directly or indirectly in any way detrimental to the interest of Purge Solutions.</p>	<p>DO NOT SCALE DRAWING UNLESS OTHERWISE SPECIFIED:</p> <p>Dimensions Are in Inches Dimensions in 1/16th in mm</p> <p>Tolerances: X - ± 0.015 XX - ± 0.010 XXX - ± 0.005</p> <p>Angular - ± 0.5° Break All Sharp Edges 6S Minimum Except As Noted</p>	<p>DRAWN: WJT DATE: 03/MAY/02</p>	<p>TITLE: FLOW FOR HEAVIER THAN AIR HAZARDOUS MATERIALS CYCLOPS Y OR Z- PURGE INDICATOR, MULTIPLE ENCLOSURES</p>
		<p>CHECKED: WJT DATE: 03/MAY/02</p>	<p>PART & DWG #: DO-11007-H-4</p>
		<p>APPROVED: WJT DATE: 03/MAY/02</p>	<p>MATERIAL: NOTED</p>
			<p>SHEET 4 OF 4</p>

<p>PURGE SOLUTIONS</p> <p>WEBSTER, TEXAS, USA 832-388-7186</p>



NOTE: Purge / Pressurization Systems Recommended Enclosure Installation for Hazardous Areas with Flammable Gasses or Vapors that are Heavier than Air are as follows:

1. The purge gas inlet supply connection should enter the enclosure near the top corner of the enclosure.
2. As such the enclosure exhaust vent should be installed near an extreme opposite bottom corner of the enclosure.
3. Refer to drawing number DO-11007-H-3 for illustration of heavier than air single enclosure flow diagram.
4. Refer to drawing number DO-11007-H-4 for illustration of heavier than air multiple enclosures flow diagram.
5. Minimum Protective Gas supply 3/8 inch O.D. or 1/4 inch I.D. pipe with a Maximum of 20 feet length and 10 bends.
6. Minimum Multi-Enclosure connections 1 1/2 inch I.D. pipe or tubing with a Maximum of 12 feet length and 6 bends.

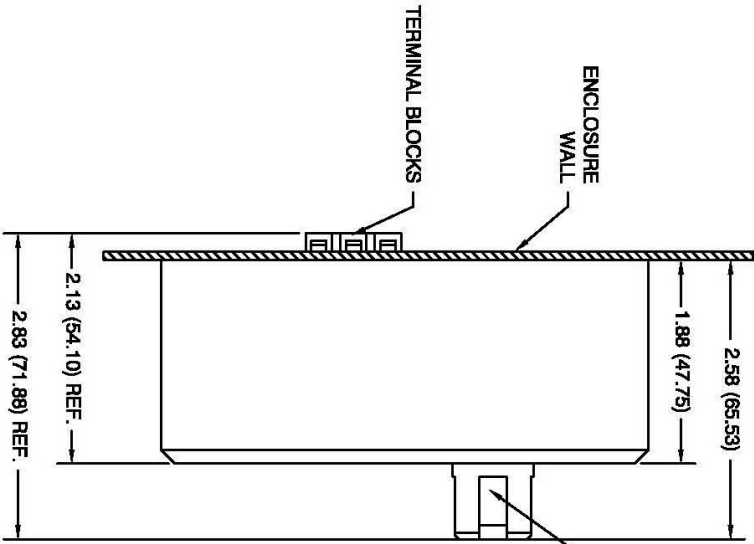

SIDE VIEW

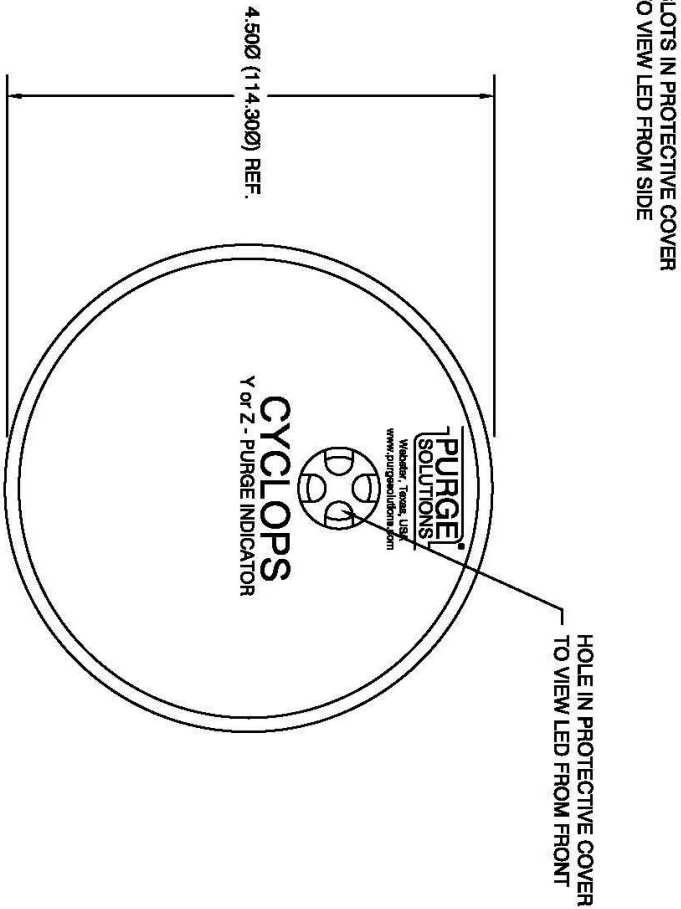

FRONT VIEW

REV #		ECO #		DATE		CHANGE BY		APPD BY	
CHANGE(S) DESCRIPTION									

<p>DO NOT SCALE DRAWING UNLESS OTHERWISE SPECIFIED</p> <p>Dimensions Are in Inches Dimensions in () Are in mm</p> <p>Tolerances: X = ± 0.015 XX = ± 0.010 XXX = ± 0.005</p> <p>Angle = 5° 8° Break At Sharp Edges Minimum Except As Noted</p>					<p>DRAWN: WJT DATE: 05/MAY/11</p>		<p>TITLE: DIMENSIONAL GENERAL ASSEMBLY CYCLOPS Y OR Z - PURGE INDICATOR</p>		<p>DATE: 05/MAY/11</p>		<p>PURGE SOLUTIONS WEBSTER, TEXAS, USA 832-368-7168</p>	
<p>The contents of this drawing is the sole property of Purge Solutions. This print and/or its contents shall not be traced or reproduced without prior written permission from Purge Solutions. It shall not be used directly or indirectly in any way detrimental to the interest of Purge Solutions.</p>					<p>CHECKED: WJT DATE: 05/MAY/11</p>		<p>PART & DWG #: DO-11143-A</p>		<p>MATERIAL: N/A</p>			
<p>APPROVED: WJT DATE: 05/MAY/11</p>					<p>SHEET 1 OF 1</p>		<p>SCALE: N/A</p>		<p>DWG SIZE: A</p>			
					<p>FINISH: N/A</p>							

TOP OF CYCLOPS Y OR Z - PURGE INDICATOR MOUNTING HOLE PATTERN

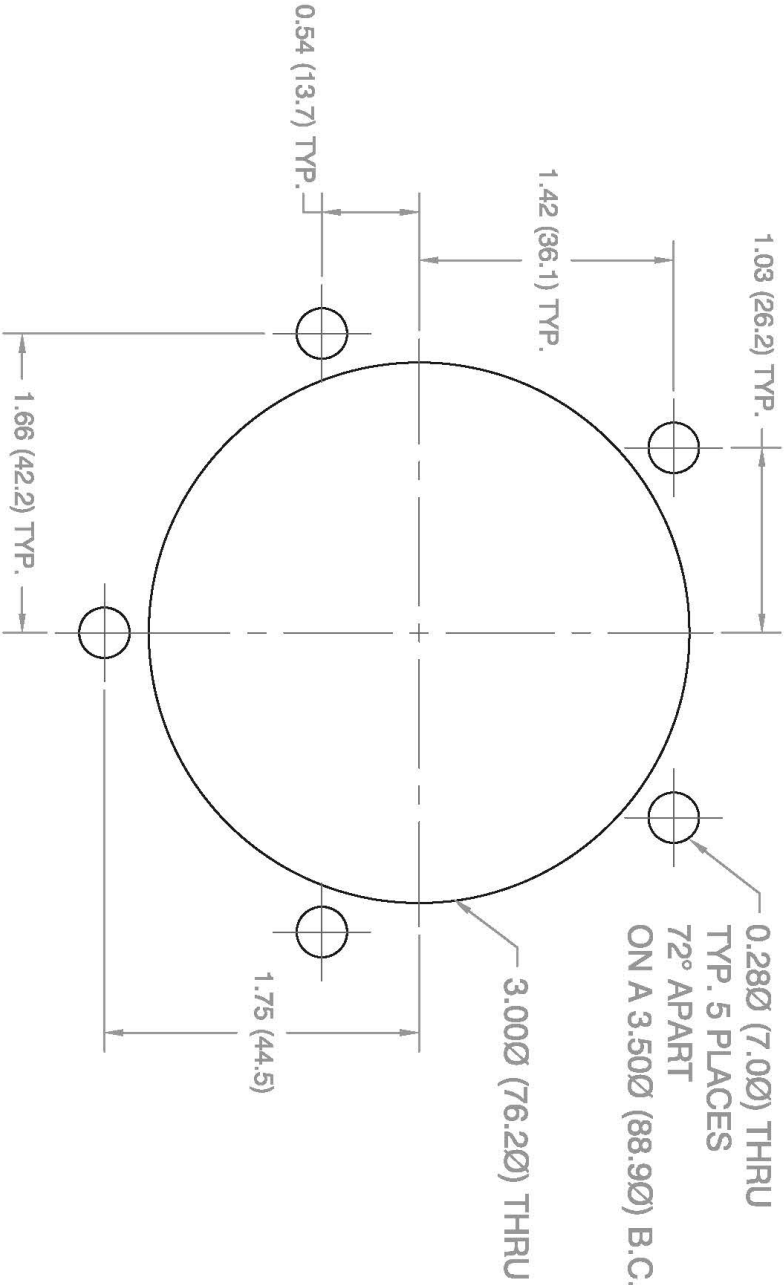

REV #	ECO #	<p>The contents of this drawing is the sole property of Purge Solutions. This print and/or its contents shall not be traced or reproduced without prior written permission from Purge Solutions. It shall not be used directly or indirectly in any way detrimental to the interest of Purge Solutions.</p>	<p>DO NOT SCALE DRAWING. UNLESS OTHERWISE SPECIFIED: Dimension in Inches Tolerance: X = ± 0.015 XX = ± 0.010 XXX = ± 0.005 Angular = ± 0.5° Break All Sharp Edges 93 Withstand Impact & Heat</p>	<p>CHANGE(S) DESCRIPTION</p>	DATE	CHANGE BY	APPD BY
		<p>DRAWN: WJT DATE: 02/AUG/02</p> <p>CHECKED: WJT DATE: 02/AUG/02</p> <p>APPROVED: WJT DATE: 02/AUG/02</p>	<p>TITLE: HOLE MOUNTING TEMPLATE CYCLOPS Y OR Z - PURGE INDICATOR</p> <p>PART & DWG #: DO-11008-D</p> <p>SHEET 1 OF 1</p> <p>SCALE: N/A</p>	<p>MATERIAL: N/A</p> <p>FINISH: N/A</p>	<p>WEBSTER, TEXAS, USA 832-388-7188</p>		

Step 5: Drill or punch all holes, per the sizes and locations specified on the Mounting Hole Template drawing number DO-11008-C.

Step 6: Before mounting the CYCLOPS Z – Purge Indicator install the o-ring provided into its appropriate groove. Next, line up CYCLOPS Z – Purge Indicator on the outside of enclosure, aligning the CYCLOPS Z – Purge Indicator to the mounting holes produced in Step 5.

Step 7: Using the five (5) each stainless steel, 1/4–20 UNC x 1/2 long screws, flat and split lock washers provided, mount the CYCLOPS Z – Purge Indicator to enclosure. Tighten bolts until the o-ring seal is completely compressed against the surface of the enclosure to a minimum torque setting of 5 Foot Pound (6.7 Meter Newton) using a #3 Phillips head tool.



WARNING: This apparatus must be earth grounded! Refer to Figure 1 for proper ground connection details.

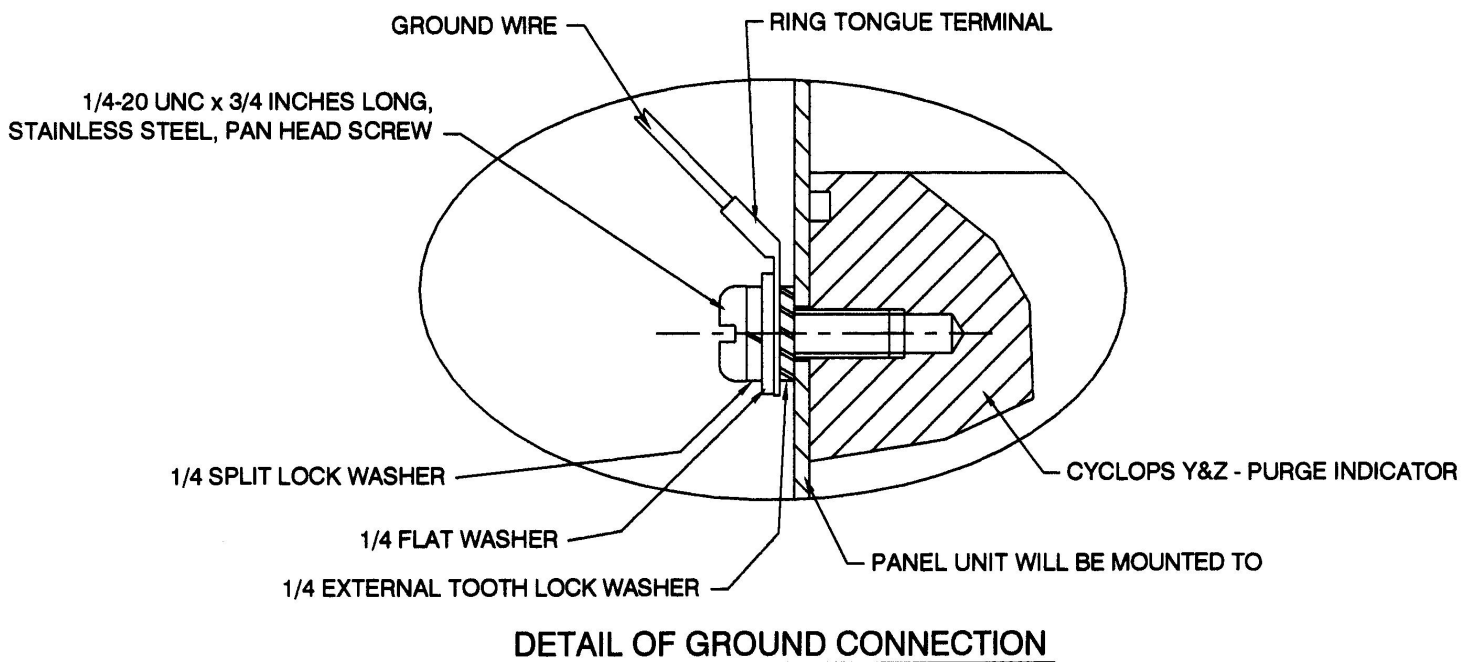

Figure 1



CAUTION: Electrical power wiring must be checked for correct size and routing.

Electrical Supply Power Installation:

TERMINAL BLOCK - J1	TERMINAL BLOCK - J1	TERMINAL BLOCK - J1	TERMINAL BLOCK - J1
12 VOLT DC VERSION	24 VOLT DC VERSION	115 VOLT AC VERSION	230 VOLT AC VERSION
A POSITION - 1, +DC	A POSITION - 1, +DC	A POSITION - 1, LINE	A POSITION - 1, LINE 1
B POSITION - 2, -DC	B POSITION - 2, -DC	B POSITION - 2, NEUTRAL	B POSITION - 2, LINE 2
C POSITION - 3, CHASSIS	C POSITION - 3, CHASSIS	C POSITION - 3, GROUND	C POSITION - 3, EARTH

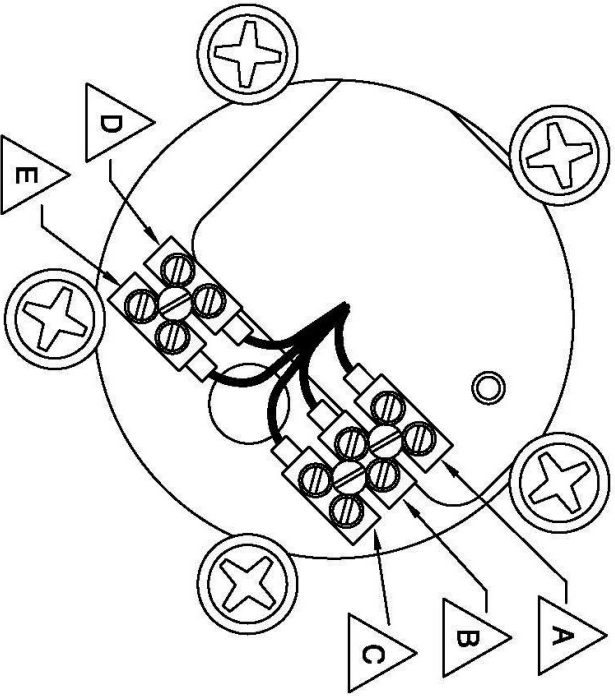

TERMINAL BLOCK - J2
ALARM TERMINALS
D POSITION - 1 (STANDARD) OPEN ON ALARM (OPTIONAL) CLOSED ON ALARM
E POSITION - 2, RETURN

POWER CONTACT RATINGS
250 VAC, 47 - 63Hz
10 Amp MAX CURRENT
ALARM CONTACT RATINGS
265 VAC, 47 - 63Hz
150mA MAX CURRENT

REV #	ECC #	CHANGE(S) DESCRIPTION	DATE	CHANGE BY	APPD BY
<p>DO NOT SCALE DRAWING UNLESS OTHERWISE SPECIFIED: Dimensions As Shown Directions in () See Item Tolerances: X = ± 0.015 XX = ± 0.010 XXX = ± 0.005 Angular = ± 0.5° Break All Sharp Edges 89 Minimum Gaps As Noted</p>					
<p>The contents of this drawing is the sole property of Purge Solutions. This print and/or its contents shall not be traced or reproduced without prior written permission from Purge Solutions. It shall not be used directly or indirectly in any way detrimental to the interest of Purge Solutions.</p>		<p>DO NOT SCALE DRAWING UNLESS OTHERWISE SPECIFIED: Dimensions As Shown Directions in () See Item Tolerances: X = ± 0.015 XX = ± 0.010 XXX = ± 0.005 Angular = ± 0.5° Break All Sharp Edges 89 Minimum Gaps As Noted</p>			
<p>DRAWN: WJT DATE: 04/AUG/02</p>		<p>TITLE: CUSTOMER WIRING DIAGRAM CYCLOPS Y OR Z - PURGE INDICATOR</p>		<p>SCALE: N/A DWG SIZE: A</p>	
<p>CHECKED: WJT DATE: 04/AUG/02</p>		<p>PART & DWG #: DO-11009-F</p>		<p>MATERIAL: N/A</p>	
<p>APPROVED: WJT DATE: 04/AUG/02</p>		<p>SHEET: 1 OF 1</p>		<p>FINISH: N/A</p>	
<p>PURGE SOLUTIONS WEBSTER, TEXAS, USA 832-388-7188</p>					

Step 8: Connect a minimum 16 AWG, stranded, three-conductor wire; refer to Power Source Specifications for power to the CYCLOPS Z – Purge Indicator. Refer to Wiring Diagram drawing number DO-11009-F for wire terminal strip locations.



NOTE: Refer to Power Source Specifications, Power Connection tables and Wiring Diagram number DO-11009-F for connecting power to the CYCLOPS Z – Purge Indicator.

Supply Power Source Specification
115 VAC Model, 50 / 60 Hz 230 VAC Model, 50 / 60 Hz 12 VDC Model, polarity-protected 24 VDC Model, polarity-protected
Use minimum 16 AWG cross section, 0.032 (0.81mm) insulation thickness, power wire rated for at least 250 VAC
Tighten terminal block screws to a minimum torque setting of 3 Inch Pound (0.4 Meter Newton) using a 1/8" (3mm) slotted head tool

Power Connection	
WIRE	TERMINAL NUMBER
Hot 1 or + Supply	Terminal Block – 1 Position – 1
Neutral or Hot 2 Or Return	Terminal Block – 1 Position – 2
Ground, Earth, or Chassis	Terminal Block – 1 Position – 3

Dry Contact Alarm Signal Installation:

Step 9: Connect a minimum 20 AWG, stranded, two-conductor wire; refer to Alarm Source Specifications for alarm signal to the CYCLOPS Z – Purge Indicator. Use Wiring Diagram drawing number DO-11009-F for wire terminal strip locations.



NOTE: The CYCLOPS Z – Purge Indicator provides a dry alarm contact for use by the customer. For hook-up and use of the alarm contact provided by the Purge Indicator, consult the following Alarm Source Specifications, Alarm Connection tables and Wiring Diagram drawing number DO-11009-F.

Alarm Source Specifications
Alarm Contact is Rated for Maximum Continuous Load Current of 150 mA rms AC Voltage and 150 mA DC Voltage
Use a minimum 20 AWG, cross section, 0.032 (0.81mm) insulation thickness, power wire rated for at least 300 V
Tighten terminal block screws to a minimum torque setting of 3 Inch Pound (0.4 Meter Newton) using a 1/8" (3mm) slotted head screwdriver

Alarm Connection	
ALARM TERMINAL	TERMINAL NUMBER
Loss of Minimum Overpressure; when pressure in enclosure being monitored is below 0.30 inch H ₂ O or (0.75 mbar) for explosive gas atmospheres or 0.5 inch H ₂ O (1.25 mbar) for combustible dust atmospheres	Terminal Block – 2 Position – 1
Alarm Contact is Normally Open “NO” when there is Loss of Minimum Overpressure inside enclosure	
Alarm Contact is Normally Closed “NC” when there is Loss of Minimum Overpressure inside enclosure	
Return for position one	Terminal Block – 2 Position – 2

Step 10: After routing and terminating the wires into the terminal strips on the CYCLOPS Z – Purge Indicator, secure these wires using proper lead dress.

Protective Gas Inlet Kit Installation Procedures:



WARNING: *The purge and pressurization system installation must include a Continuous Dilution or Manual Leakage Compensation Purge Gas Inlet Kit along with a UL Classified Type Z - Indicator.*

Review all the material in this IOM Manual prior to installing any Protective Gas Inlet Kit. If you have any questions, please contact your local Purge Solutions, Inc. representative or the factory; refer to Getting Help page 57 or view installation video, which can be found on our web site www.purgesolutions.com. Refer to Installation Flow Diagrams drawing numbers DO-11007-J-1 through 4, refer to pages 14 through 17.



NOTE: *Selection of Protective Gas Inlet Kit and flow rate should be based on available protective gas volume at installation site; not on maximum volume of protective gas that selected Protective Gas Inlet Kit can supply.*

Step 1: Make sure that area surrounding enclosure that Protective Gas Inlet Kit will be installed; is known to be non-hazardous.

Step 2: Make sure that all power is disconnected from the electrical equipment located in the panel that Protective Gas Inlet Kit will be installed.

Step 3: Select a mounting location for the Protective Gas Inlet Kit that would best purge and pressurize enclosure, refer to Installation Flow Diagrams drawing numbers DO-11007-J-1 through 4, refer to pages 14 through 17 for possible mounting locations. ***Protective Gas Inlet Kits are not orientation sensation and can be mounted on any side, top or bottom of enclosure. The chosen mounting location should permit adequate viewing and interface for required pressure / flow adjustment.***

Step 4: Use the 1 to 1 Hole Template shipped with each unit or create a 1 to 1 template using Continuous Dilution Protective Gas Inlet Kit or Manual Leakage Compensation Protective Gas Inlet Kit Mounting Hole Pattern drawings to accurately locate mounting holes and gas ports. Tape the 1 to 1 template to the **outside** of enclosure. The required hole locations can then be transferred using the centers of the holes as shown on the drawings.

Step 5: Drill or punch all holes, per the sizes specified on Continuous Dilution Protective Gas Inlet Kit or Manual Leakage Compensation Protective Gas Inlet Kit Mounting Hole Pattern drawings.

Step 6: Before mounting the Protective Gas Inlet Kit; assemble pressure gauge to proper side of pressure regulator, plug other side hole with plug provided and install the O-ring(s) provided into its appropriate mounting fitting groove. Next, align the Protective Gas Inlet Kit manifold to the mounting holes fabricated in Step 5.

Step 7: For Continuous Dilution Protective Gas Inlet Kit use mounting fitting with O-ring and #10-32 screw with sealing washer or for Manual Leakage Compensation Protective Gas Inlet Kit use the mounting fittings with O-rings to mount the Protective Gas Inlet Kit to enclosure. Tighten mounting fitting and screw until each seals against the surface of the enclosure to a minimum torque setting of 25 – 30 in lbs. (2.8 – 3.4 Nm).

Step 8: After Protective Gas Inlet Kit has been installed; connect protective gas supply line to the Protective Gas Inlet Kit pressure regulator inlet port. Refer to Continuous Dilution Protective Gas Inlet Kit or Manual Leakage Compensation Protective Gas Inlet Kit drawings for protective gas inlet port size.

Step 9: Once the protective gas supply has been connected to the Protective Gas Inlet Kit pressure regulator protective gas inlet port; the Protective Gas Inlet Kit is ready to supply protective gas to panel.

Protective Gas Inlet Kit Model Number Matrix

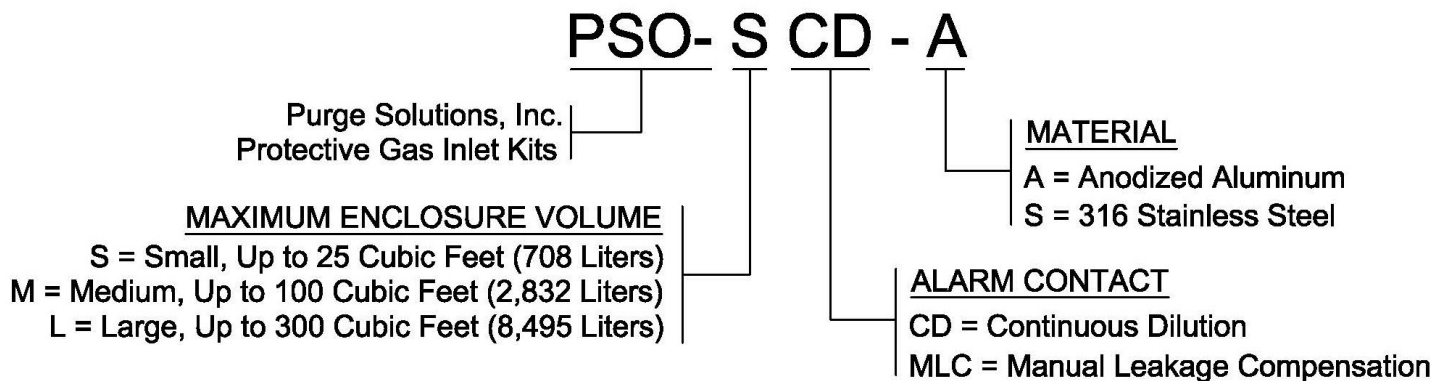

NOTE: Selection of Protective Gas Inlet Kit and flow rate should be based on available protective gas volume at installation site; not on maximum volume of protective gas that selected Protective Gas Inlet Kit can supply.



NOTE: Protective Gas Inlet Kits should be used in combination with CYCLOPS Indicators as follows: Small for enclosures with volumes up to 25 Cubic Feet (708 Liters), Medium for enclosures with volumes up to 100 Cubic Feet (2,832 Liters) and Large for enclosures with volumes up to 300 Cubic Feet (8,495 Liters).

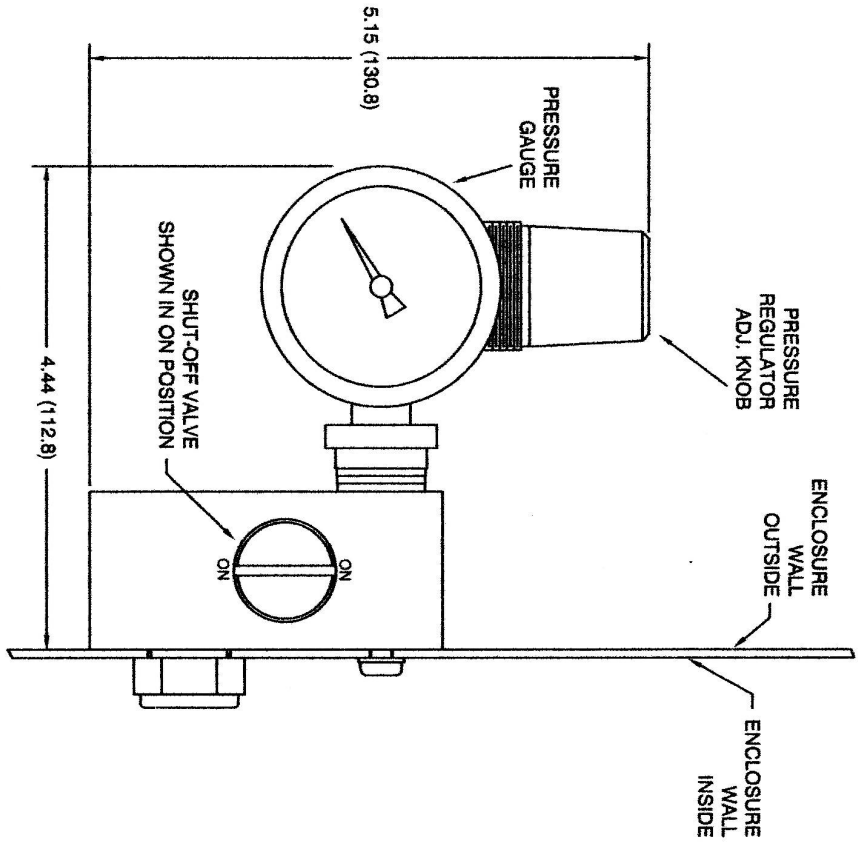

NOTE: PURGE GAS INLET = 1/4 - 18 FNPT

FRONT VIEW

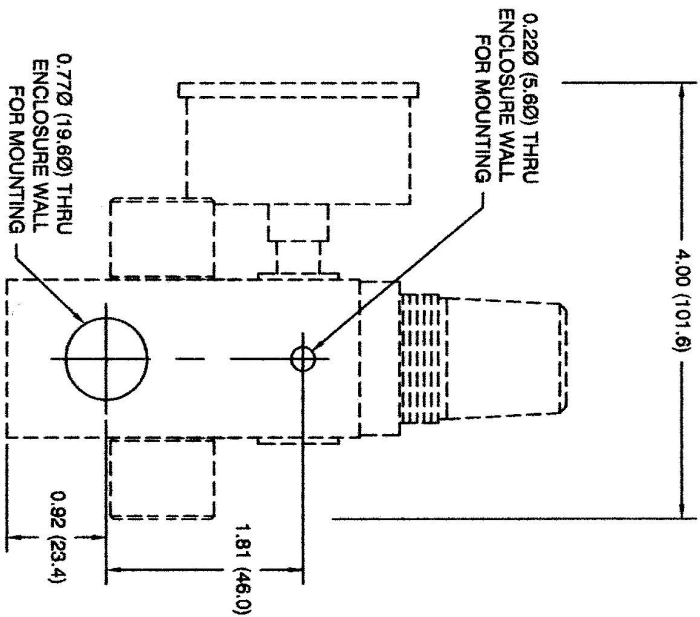

**SIDE VIEW
MOUNTING HOLE PATTERN**

REV #	ECO #	CHANGE(S) DESCRIPTION	DATE	CHANGE BY	APPD BY

<p>DO NOT SCALE DRAWING UNLESS OTHERWISE SPECIFIED. Dimension in () Are in mm Tolerances: X = ± 0.010 (0.25) XX = ± 0.010 (0.25) XXX = ± 0.008 (0.13) Angular = ± 0.5° Break at Sharp Edges CS Minimum Except As Noted</p>		<p>DRAWN: WJT DATE: 09/DEC/08</p>	<p>TITLE: SMALL CONTINUOUS DILUTION PURGE GAS INLET KIT HOLE MOUNTING PATTERN</p>	<p>DATE: 09/DEC/08</p>	<p>SCALE: N/A</p>	<p>DWG SIZE: A</p>	<p>FINISH: N/A</p>
<p>The contents of this drawing is the sole property of Purge Solutions. This print and/or its contents shall not be traced or reproduced without prior written permission from Purge Solutions. It shall not be used directly or indirectly in any way detrimental to the interest of Purge Solutions.</p>		<p>CHECKED: WJT DATE: 09/DEC/08</p>	<p>PART & DWG #: PSO-SCD</p>	<p>APPROVED: WJT DATE: 09/DEC/08</p>	<p>SHEET: 1 OF 1</p>	<p>MATERIAL: N/A</p>	<p>DATE: CHANGE BY: APPD BY:</p>



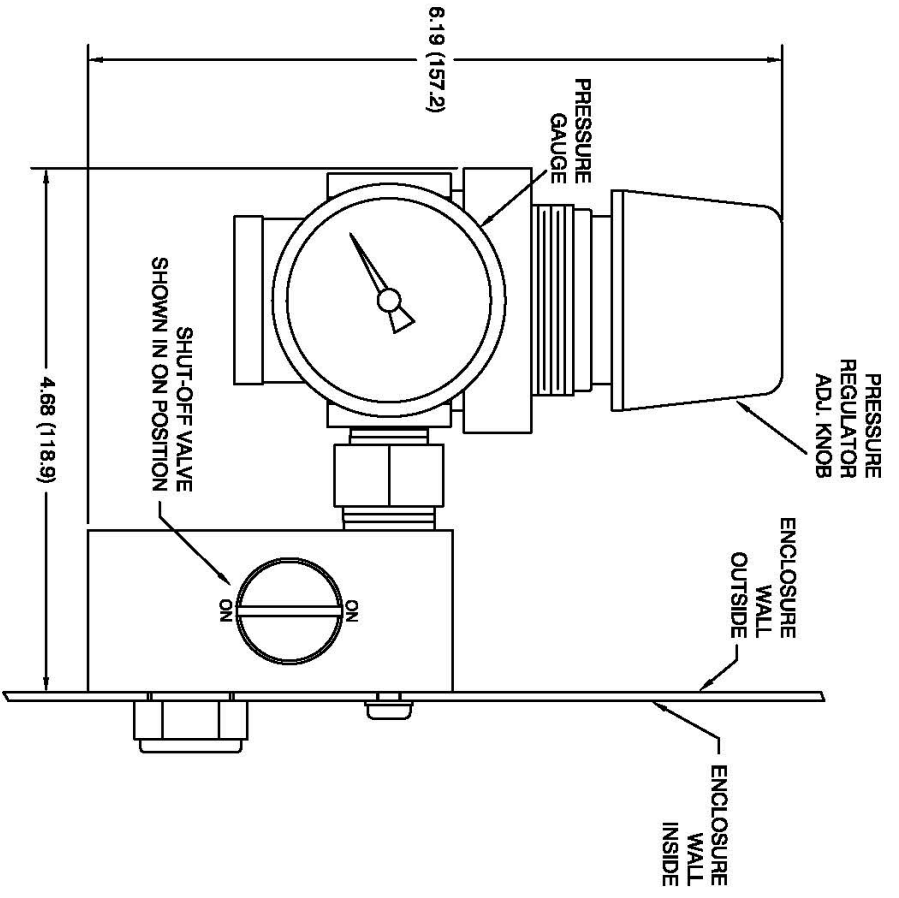

NOTE: PURGE GAS INLET = 3/8 FNPT

FRONT VIEW

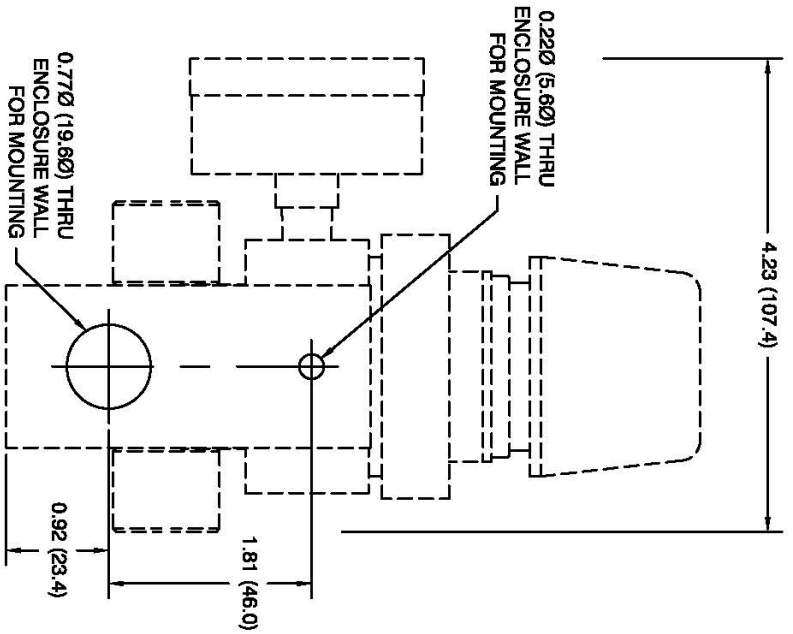

SIDE VIEW
MOUNTING HOLE PATTERN

REV #	ECO #	CHANGE(S) DESCRIPTION	DATE	CHANGE BY	APPD BY

DO NOT SCALE DRAWING
UNLESS OTHERWISE SPECIFIED:
Dimension in Inches
Dimension in () / mm in mm
Tolerances: X = ± 0.015 (0.38)
XX = ± 0.010 (0.25)
XXX = ± 0.005 (0.13)
Angular - ±0.5°
Break All Sharp Edges
63 Aluminum Except As Noted

DRAWN: WJT	CHECKED: WJT	APPROVED: WJT
DATE: 08/DEC/08	DATE: 08/DEC/08	DATE: 08/DEC/08

TITLE: MEDIUM CONTINUOUS DILUTION PURGE GAS INLET KIT	PART & DWG #: PSO-MCD	MATERIAL: N/A
SCALE: N/A	SHEET 1 OF 1	FINISH: N/A

DATE: _____ CHANGE BY: _____ APPD BY: _____

PURGE SOLUTIONS
WEBSTER, TEXAS, USA
832-368-7186

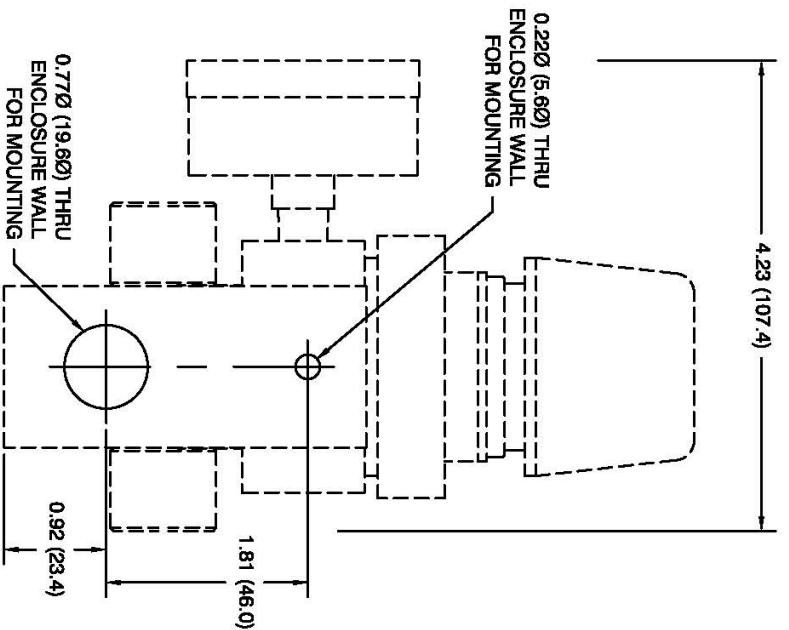
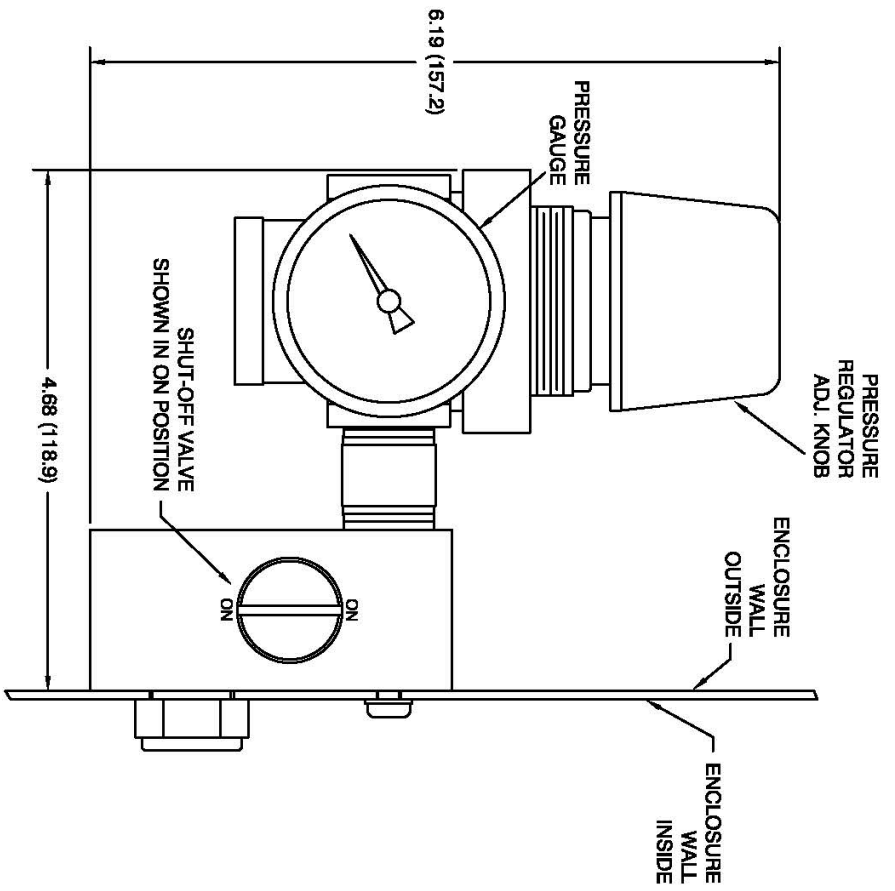

REV #	ECO #	CHANGE(S) DESCRIPTION	DATE	CHANGE BY	APPD BY

<p>DO NOT SCALE DRAWING. UNLESS OTHERWISE SPECIFIED: Dimensions Are In Inches Diameters In ()/32 In (mm) Tolerances: X" = ± 0.015 (0.38) XX" = ± 0.010 (0.25) XXX" = ± 0.005 (0.13) Angular = ±0.5° Break All Sharp Edges 83 Minimum Except As Noted</p>		<p>DRAWN: WJT DATE: 08/DEC/08</p>	<p>TITLE: LARGE CONTINUOUS DILUTION PURGE GAS INLET KIT HOLE MOUNTING PATTERN</p>	<p>SCALE: N/A</p>	<p>FINISH: N/A</p>	<p>DATE: CHANGE BY: APPD BY:</p>
<p>The contents of this drawing is the sole property of Purge Solutions. This print and/or its contents shall not be traced or reproduced without prior written permission from Purge Solutions. It shall not be used directly or indirectly in any way detrimental to the interest of Purge Solutions.</p>		<p>CHECKED: WJT DATE: 08/DEC/08</p>	<p>PART & DWG #: PSO-LCD</p>	<p>SHEET: 1 OF 1</p>	<p>MATERIAL: N/A</p>	
<p>APPROVED: WJT DATE: 08/DEC/08</p>		<p>SCALE: N/A</p>	<p>DWG SIZE: A</p>	<p>PURGE SOLUTIONS WEBSTER, TEXAS, USA 832-388-7196</p>		

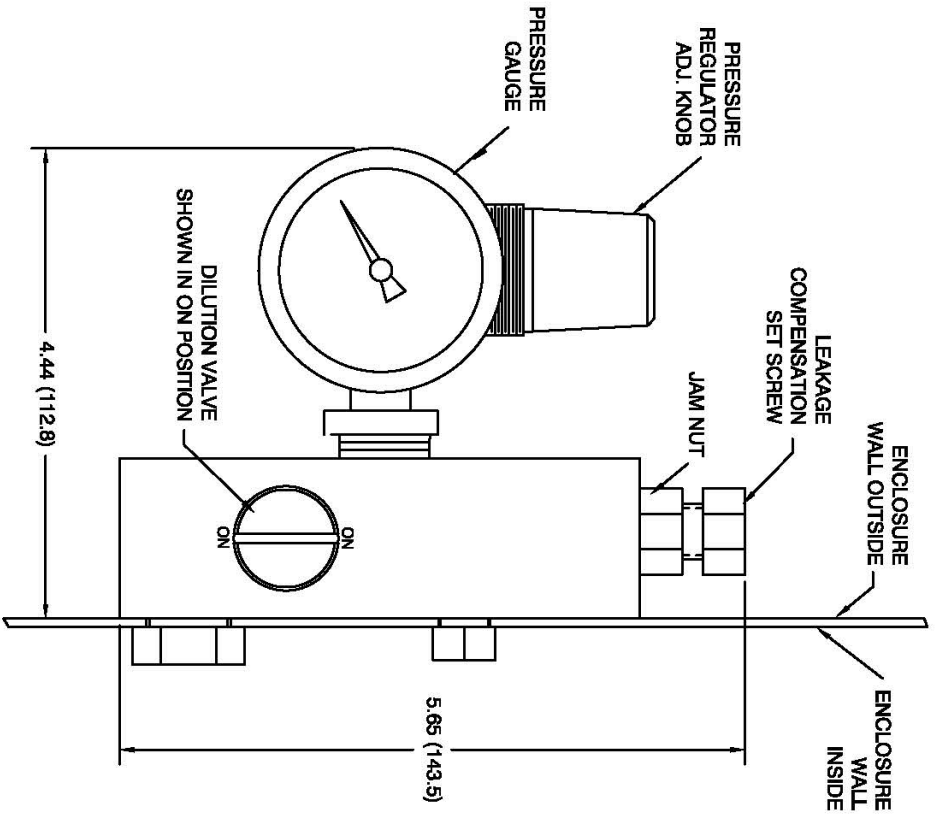

FRONT VIEW
 SHOWN IN FAST DILUTION ON POSITION
 NOTE: PURGE GAS INLET = 1/4-18 FNPT

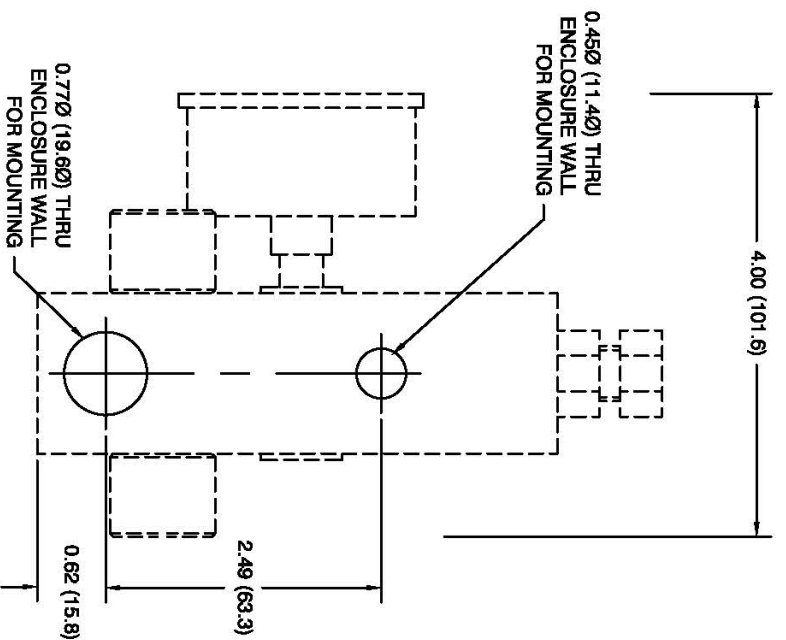

SIDE VIEW
 MOUNTING HOLE PATTERN

REV #	ECO #	CHANGE(S) DESCRIPTION	DATE	CHANGE BY	APPD BY
-------	-------	-----------------------	------	-----------	---------

<p>The contents of this drawing is the sole property of Purge Solutions. This print and/or its contents shall not be traced or reproduced without prior written permission from Purge Solutions. It shall not be used directly or indirectly in any way detrimental to the interest of Purge Solutions.</p>		<p>DO NOT SCALE DRAWING. UNLESS OTHERWISE SPECIFIED: Dimension in Inches Dimension in () are in mm Tolerances: X" = ± 0.015 XX" = ± 0.010 .XXX = ± 0.005 Angular = ±0.5° Break All Sharp Edges 63 Minimum Except As Noted</p>		<p>TITLE: SMALL MANUAL LEAKAGE COMPENSATION PURGE GAS INLET KIT</p>		<p>PURGE SOLUTIONS ALVIN, TEXAS, USA 832-388-7196</p>
<p>DRAWN: WJT DATE: 19/JAN/2019</p>		<p>CHECKED: WJT DATE: 19/JAN/2019</p>		<p>APPROVED: WJT DATE: 19/JAN/2019</p>		
<p>PART & DWG #: PSO-SMLC</p>		<p>MATERIAL: N/A</p>		<p>SHEET 1 OF 1</p>		
<p>SCALE: N/A</p>		<p>DWG SIZE A</p>		<p>FINISH: N/A</p>		

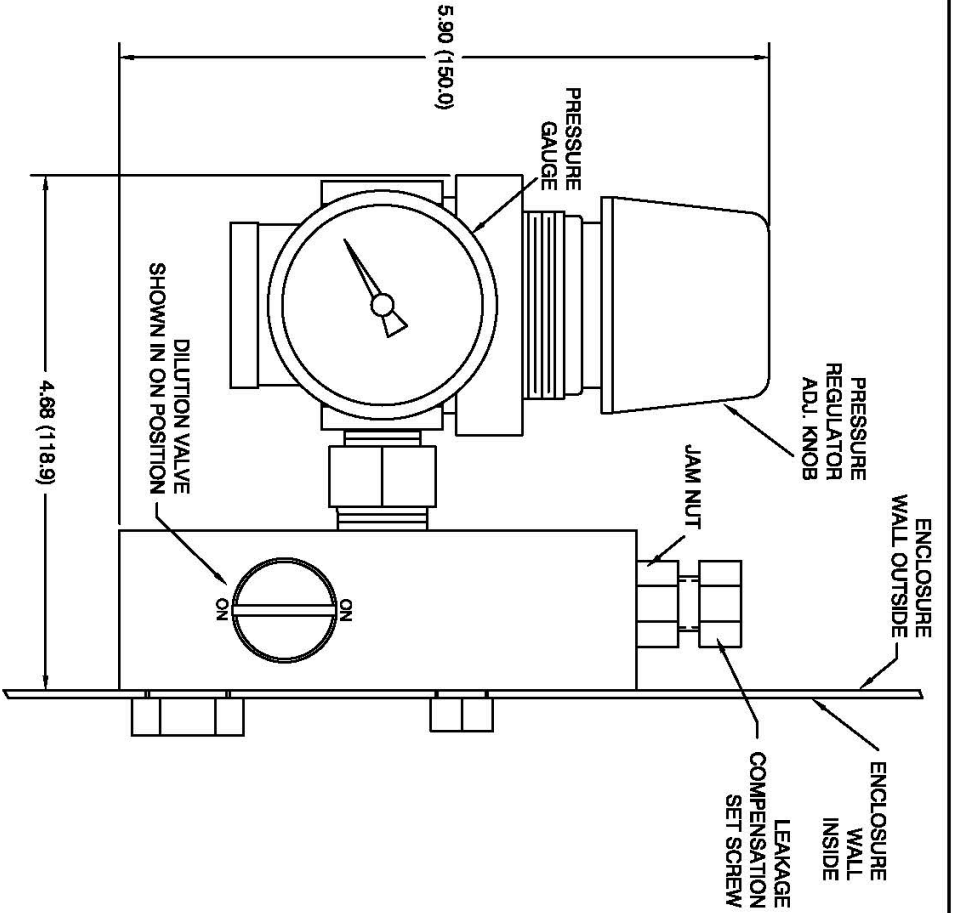

FRONT VIEW
 SHOWN IN FAST DILUTION ON POSITION
NOTE: PURGE GAS INLET = 3/8-18 FNPT

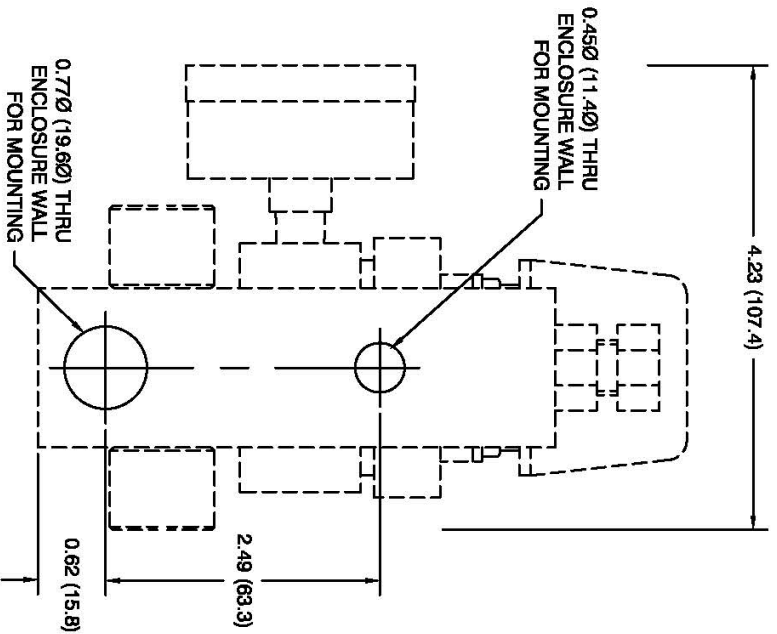

SIDE VIEW
 MOUNTING HOLE PATTERN

REV # ECO #

CHANGE(S) DESCRIPTION

DATE

CHANGE BY

APPD BY

The contents of this drawing is the sole property of Purge Solutions. This print and/or its contents shall not be traced or reproduced without prior written permission from Purge Solutions. It shall not be used directly or indirectly in any way detrimental to the interest of Purge Solutions.

DO NOT SCALE DRAWING.
 UNLESS OTHERWISE SPECIFIED:
 Dimensions Are In Inches
 Tolerances: X = ± 0.015
 XX = ± 0.010
 XXX = ± 0.005
 Angles - 10.5°
 Break All Sharp Edges
 83 Minimum Except As Noted

DRAWN: WJT
 DATE: 19/JAN/18
 CHECKED: WJT
 DATE: 19/JAN/18
 APPROVED: WJT
 DATE: 19/JAN/18

TITLE: MEDIUM MANUAL LEAKAGE COMPENSATION
 PURGE GAS INLET KIT, HOLE MOUNTING PATTERN
 PART & DWG #: PSO-MMLC
 SHEET N/A OF 1
 SCALE: N/A
 DWG SIZE: A

MATERIAL: NOTED
 FINISH: N/A



ALVIN, TEXAS, USA
 832-388-7166

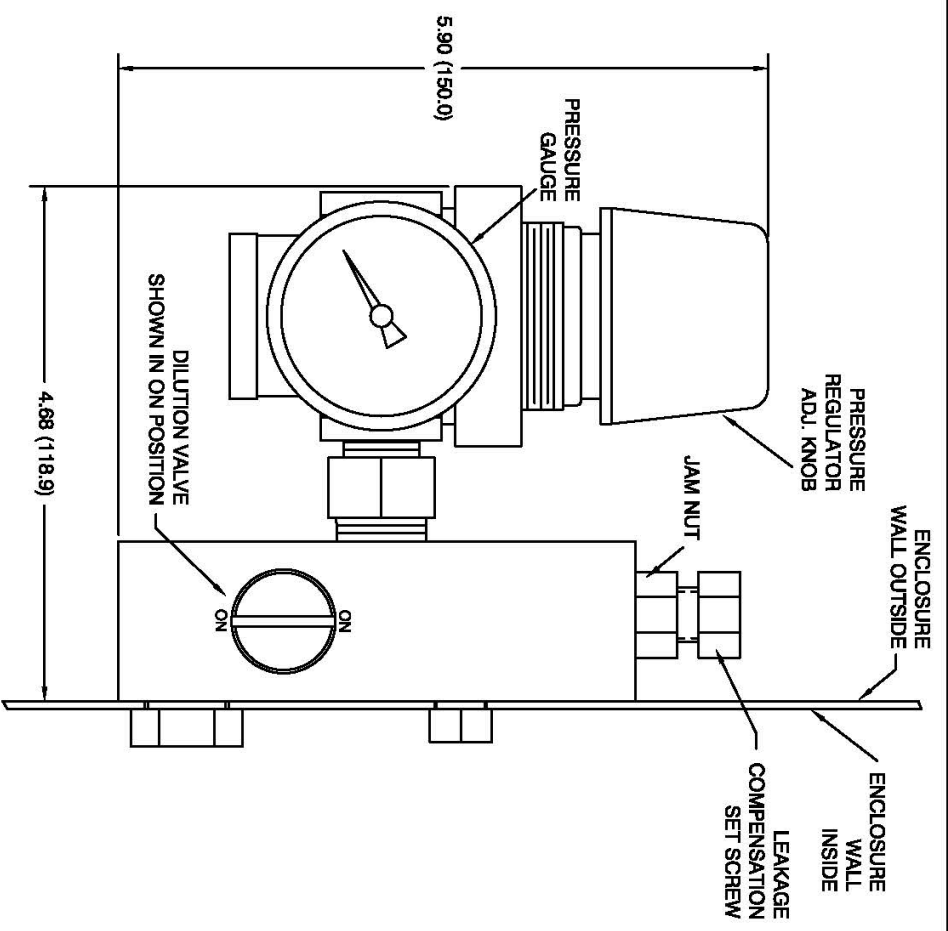

FRONT VIEW
SHOWN IN FAST DILUTION ON POSITION
NOTE: PURGE GAS INLET = 1/2-14 FNPT

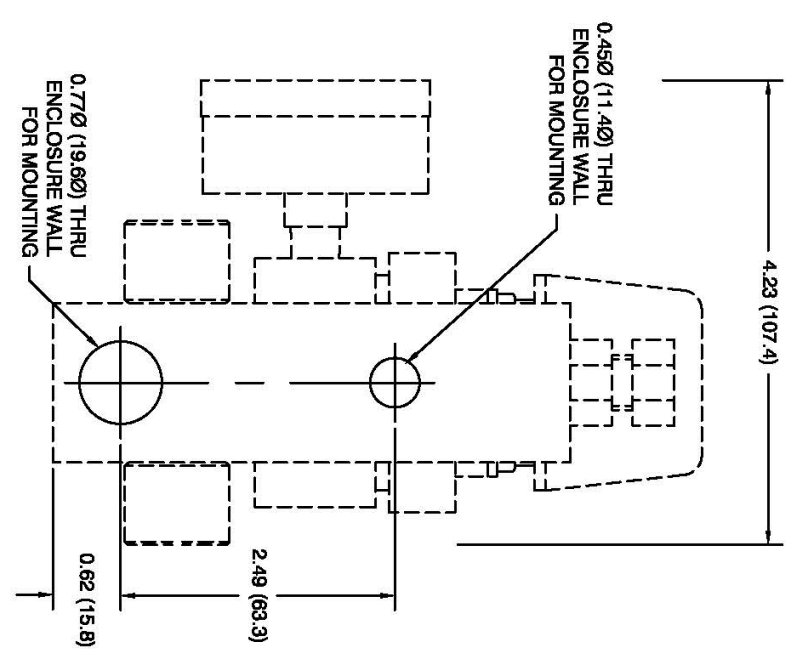

SIDE VIEW
MOUNTING HOLE PATTERN

REV #	ECO #	CHANGE(S) DESCRIPTION		DATE	CHANGE BY	APPD BY	
<p>The contents of this drawing is the sole property of Purge Solutions. This print and/or its contents shall not be traced or reproduced without prior written permission from Purge Solutions. It shall not be used directly or indirectly in any way detrimental to the interest of Purge Solutions.</p>		<p>DO NOT SCALE DRAWING. UNLESS OTHERWISE SPECIFIED, Dimensions are in inches Dimensions in () are in mm Tolerances: X = ± 0.016 (0.25) XX = ± 0.010 (0.25) XXX = ± 0.005 (0.13) Angles = ± 0.5° Break All Sharp Edges SD Minimum Except As Noted</p>		<p>DRAWN: WJT DATE: 19/JAN/18</p> <p>CHECKED: WJT DATE: 19/JAN/18</p> <p>APPROVED: WJT DATE: 19/JAN/18</p>		<p>TITLE: LARGE MANUAL LEAKAGE COMPENSATION PURGE GAS INLET KIT, HOLE MOUNTING PATTERN</p> <p>PART & DWG #: PSO-LMLC</p> <p>SHEET: N/A OF 1</p> <p>SCALE: N/A</p> <p>DWG SIZE: A</p> <p>MATERIAL: NOTED</p> <p>FINISH: N/A</p>	
<p>WEBSTER, TEXAS, USA 832-388-7198</p>							

Back – Up Exhaust Vent Installation Procedures:

 **NOTE:** *Back – Up Exhaust Vents are required for all Dust Applications; as primary exhaust port built into CYCLOPS Indicator housing is plugged and Back – Up Exhaust Vent is used as follows: Small Exhaust Vent for enclosure volumes up to 25 Cubic Feet (708 Liters), Medium Exhaust Vent for enclosure volumes up to 100 Cubic Feet (2,832 Liters) and Large Exhaust Vent for enclosure volumes up to 200 Cubic Feet (5,663 Liters).*

 **NOTE:** *A Back – Up Exhaust Vent is required for Gas Applications in addition to primary exhaust port built into CYCLOPS Indicator housing for applications with enclosure volumes over 100 Cubic Feet (2,832 Liters) as follows: an additional Medium Exhaust Vent for enclosure volumes up to 200 Cubic Feet (5,663 Liters) and an additional Large Exhaust Vent for enclosure volumes up to 300 Cubic Feet (8,495 Liters).*

Review all the material in this IOM Manual prior to installing any Back – Up Exhaust Vent. If you have any questions, please contact your local Purge Solutions, Inc. representative or the factory; refer to Getting Help page 57. Refer to Installation Flow Diagrams drawing numbers DO-11007-J-1 through 4, refer to pages 14 through 17.

Step 1: Make sure that area surrounding enclosure that Back – Up Exhaust Vent will be installed; is known to be non-hazardous.

Step 2: Make sure that all power is disconnected from the electrical equipment located in the panel that Back – Up Exhaust Vent will be installed.

Step 3: Select a mounting location for the Back – Up Exhaust Vent that would best vent enclosure, refer to Installation Flow Diagrams drawing numbers DO-11007-J-1 through 4, refer to pages 14 through 17 for possible mounting locations. ***Back – Up Exhaust Vents are orientation sensitive and can only be mounted vertically on any side or top of enclosure.***

Step 4: Use the 1 to 1 Hole Template shipped with each unit or create a 1 to 1 template using a Small, Medium or Large Back – Up Exhaust Vent Mounting Hole drawings to accurately locate mounting hole. Tape the 1 to 1 template to the ***outside*** of enclosure. The required hole location can then be transferred using the center of the hole as shown on the drawings.

Step 5: Drill or punch all holes, per the sizes specified on Small, Medium or Large Back – Up Exhaust Vent Mounting Hole drawings.

Step 6: Before mounting the Back – Up Exhaust Vent; install the O-ring provided into its appropriate mounting fitting groove. Next, insert the Back – Up Exhaust Vent into the mounting hole fabricated in Step 5.

Step 7: Use mounting fitting nut to mount the Back – Up Exhaust Vent to enclosure. Tighten mounting fitting nut until seals against the surface of the enclosure, which will be 25 – 30 in lbs. (2.8 – 3.4 Nm).

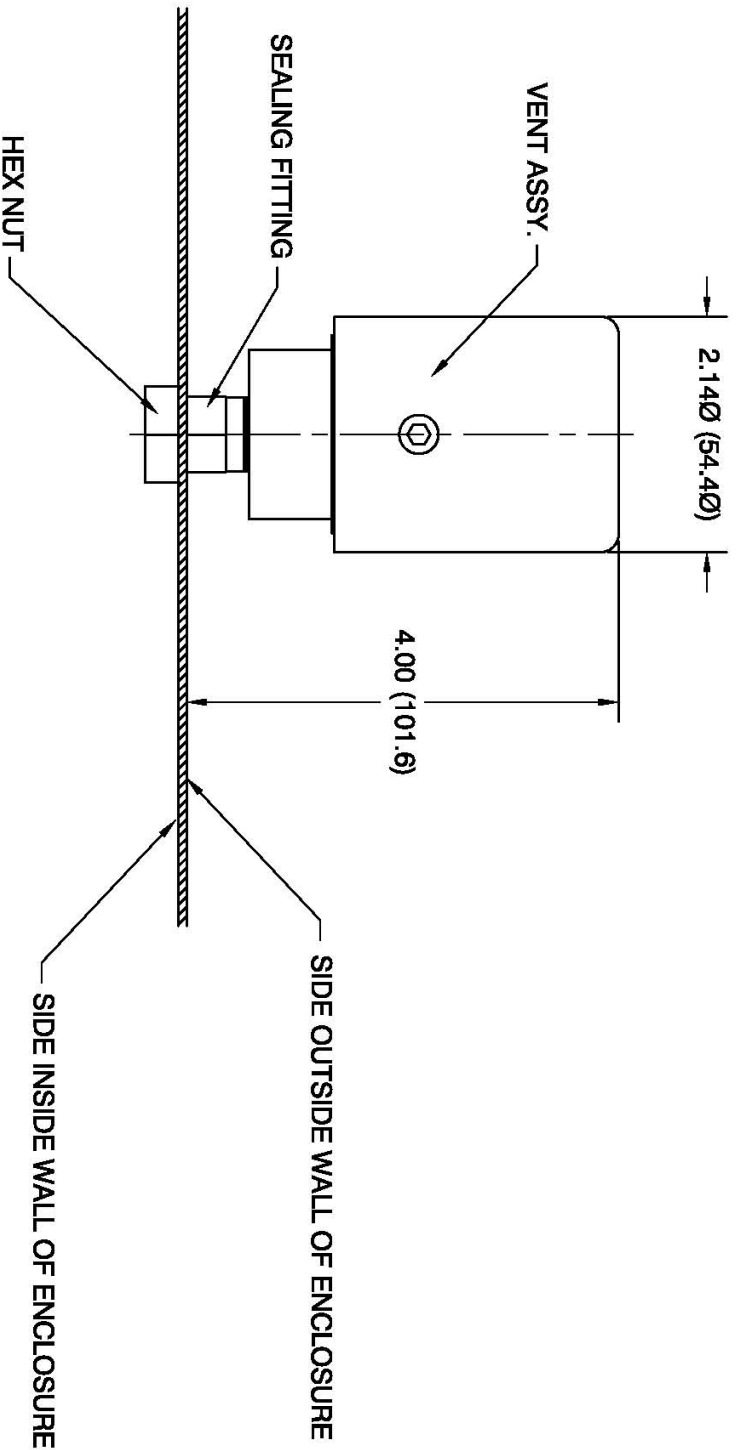

NOTES:
 REQUIRED HOLE THRU ENCLOSURE WALL
 FOR VENT IS 0.57Ø (14.5Ø)

REV #	ECO #	CHANGE(S) DESCRIPTION		DATE	CHANGE BY	APPD BY
<p>The contents of this drawing is the sole property of Purge Solutions. This print and/or its contents shall not be traced or reproduced without prior written permission from Purge Solutions. It shall not be used directly or indirectly in any way detrimental to the interest of Purge Solutions.</p> <p>DO NOT SCALE DRAWING. UNLESS OTHERWISE SPECIFIED, Dimensions Are in Inch Dimensions in () Are in mm Tolerances: X = ± 0.015 XX = ± 0.010 XXX = ± 0.005 Angles = ± 0.5° Break All Sharp Edges SD Minimum Except As Noted</p>						
DRAWN: WJT DATE: 02/JAN/04		TITLE: SMALL BACK-UP VENT KIT TOP MOUNT		MATERIAL: NOTED		
CHECKED: WJT DATE: 02/JAN/04		PART & DWG #: PSO-SBUV-T		FINISH: N/A		
APPROVED: WJT DATE: 02/JAN/04		SHEET 1 OF 1		SCALE: N/A		
		DWG SIZE A				
 <p>WEBSTER, TEXAS, USA 832-388-7198</p>						

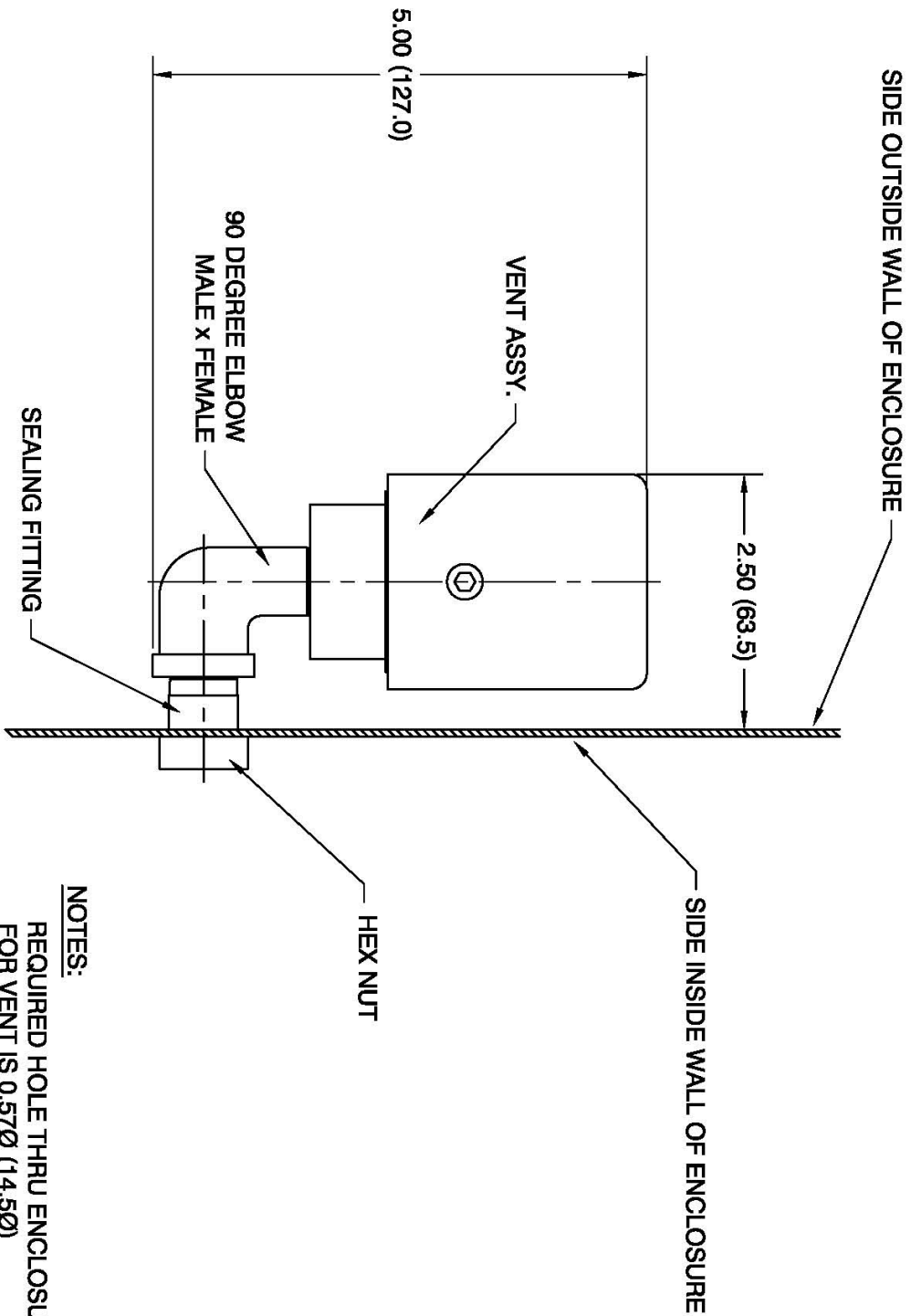

NOTES:
 REQUIRED HOLE THRU ENCLOSURE WALL
 FOR VENT IS 0.57Ø (14.5Ø)

REV #	ECO #	CHANGE(S) DESCRIPTION		DATE	CHANGE BY	APPD BY		
<p>The contents of this drawing is the sole property of Purge Solutions. This print and/or its contents shall not be traced or reproduced without prior written permission from Purge Solutions. It shall not be used directly or indirectly in any way detrimental to the interest of Purge Solutions.</p>		<p>DO NOT SCALE DRAWING. UNLESS OTHERWISE SPECIFIED, DIMENSIONS ARE IN INCHES. DIMENSIONS IN () ARE IN MM. TOLERANCES: X = ± 0.015 XX = ± 0.010 XXX = ± 0.005 Angles = ± 0.5° Break All Sharp Edges SD Minimum Except As Noted</p>		DRAWN: WJT DATE: 02/JAN/04	CHECKED: WJT DATE: 02/JAN/04	APPROVED: WJT DATE: 02/JAN/04	TITLE: SMALL BACK-UP VENT KIT SIDE MOUNT PART & DWG #: PSO-SBU-VS MATERIAL: NOTED SHEET 1 OF 1 SCALE: N/A DWG SIZE: A FINISH: N/A	 WEBSTER, TEXAS, USA 832-388-7198

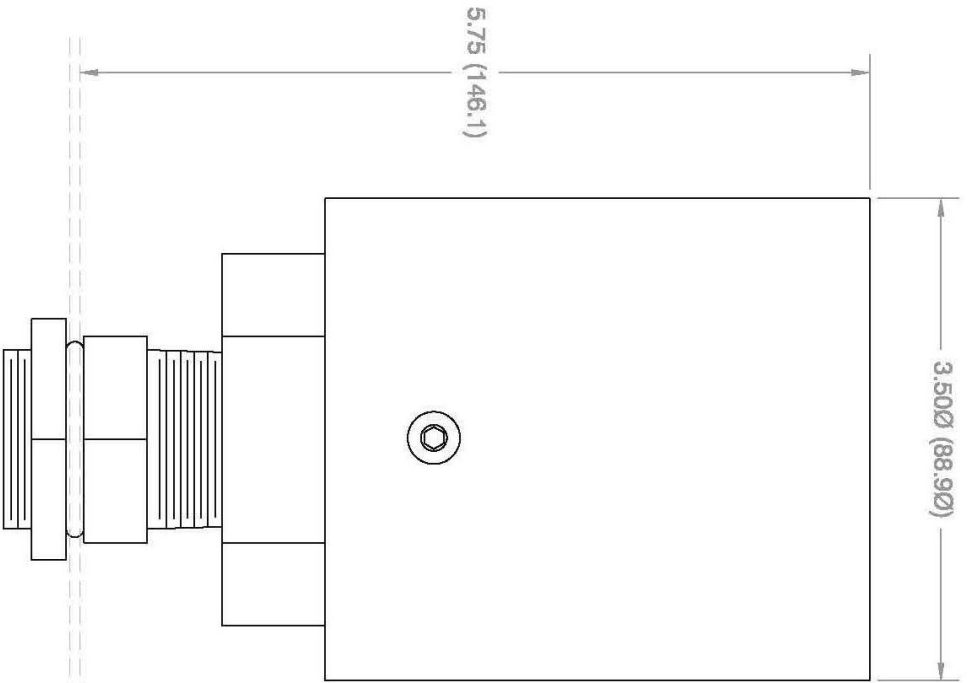

NOTES:

1. THROUGH HOLE SIZE FOR MOUNTING IS 1.311Ø (33.30).

REV #	ECCO #	CHANGE(S) DESCRIPTION	DATE	CHANGE BY	APPD BY

<p>The contents of this drawing is the sole property of Purge Solutions. This print and/or its contents shall not be traced or reproduced without prior written permission from Purge Solutions. It shall not be used directly or indirectly in any way detrimental to the interest of Purge Solutions.</p>		<p>DO NOT SCALE DRAWING UNLESS OTHERWISE SPECIFIED. Dimensions are in inches Dimensions in () are in mm Tolerances: X = ± 0.015 XX = ± 0.010 XXX = ± 0.005 Angular = ± 0.5° Break All Sharp Edges Ø = Minimum Except As Noted</p>		<p>TITLE: MEDIUM BACK-UP VENT TOP MOUNT</p>		<p>DATE: 11/JUL/08</p>
<p>DRAWN: SLM</p>		<p>CHECKED: SLM</p>		<p>APPROVED: SLM</p>		
<p>DATE: 11/JUL/08</p>		<p>PART & DWG #: PSO-MBUV-T</p>		<p>MATERIAL: N/A</p>		<p>SCALE: N/A</p>
<p>DATE: 11/JUL/08</p>		<p>SHEET: 1 OF 1</p>		<p>FINISH: N/A</p>		



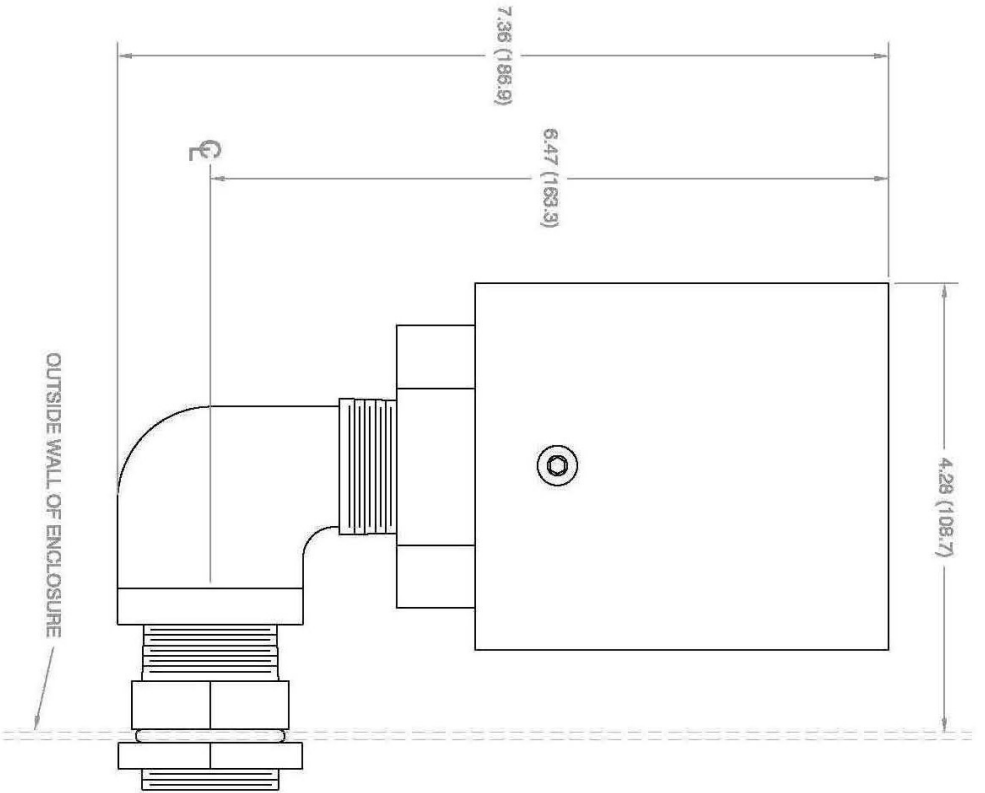

NOTES:

1. THROUGH HOLE FOR MOUNTING IS 1.31Ø (33.30).

REV #	ECC #	CHANGE(S) DESCRIPTION		DATE	CHANGE BY	APPD BY	
<p>The contents of this drawing is the sole property of Purge Solutions. This print and/or its contents shall not be traced or reproduced without prior written permission from Purge Solutions. It shall not be used directly or indirectly in any way detrimental to the interest of Purge Solutions.</p>		<p>DO NOT SCALE DRAWING UNLESS OTHERWISE SPECIFIED. Dimensions Are in Inches Dimensions in () Are in mm Tolerances: X = ± 0.015 XX = ± 0.010 XXX = ± 0.005 Angular = ± 0.5° Break All Sharp Edges BS Minimum Except As Noted</p>		<p>DRAWN: SLM DATE: 11/JUL/08</p>	<p>TITLE: MEDIUM BACK-UP VENT SIDE MOUNT</p>		
		<p>CHECKED: SLM DATE: 11/JUL/08</p>	<p>PART & DWG #: PSO-MBUV-S</p>	<p>MATERIAL: N/A</p>			
		<p>APPROVED: SLM DATE: 11/JUL/08</p>	<p>SHEET 1 OF 1 SCALE: N/A</p>	<p>DWG SIZE: A</p>	<p>FINISH: N/A</p>		
<p>WEBSTER, TEXAS, USA 832-398-7198</p>							

NOTES:
 1. REQUIRED HOLE THRU ENCLOSURE WALL FOR VENT IS 2.38Ø (60.5Ø)

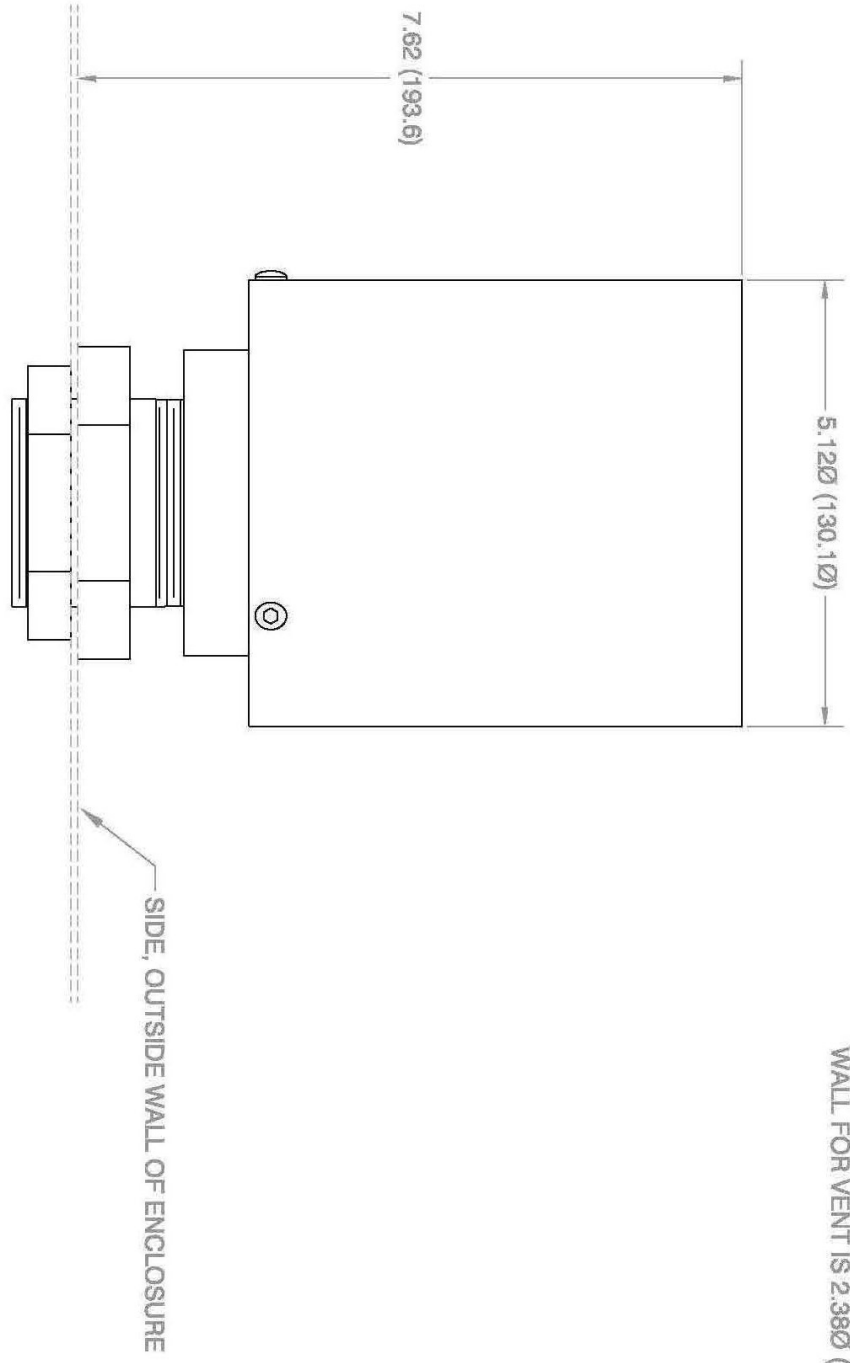

REV # ECO #

The contents of this drawing is the sole property of Purge Solutions. This print and/or its contents shall not be traced or reproduced without prior written permission from Purge Solutions. It shall not be used directly or indirectly in any way detrimental to the interest of Purge Solutions.

DO NOT SCALE DRAWING
 UNLESS OTHERWISE SPECIFIED
 Dimensions are in inches
 Dimensions in () are in mm
 Tolerance: X = ± 0.015
 XX = ± 0.010
 XXX = ± 0.005
 Angular = ± 0.5°
 Break All Sharp Edges
 BS Minimum Except As Noted

DRAWN: WJT
 DATE: 16/OCT/09
 CHECKED: WJT
 DATE: 16/OCT/09
 APPROVED: WJT
 DATE: 16/OCT/09

TITLE: LARGE BACK-UP VENT TOP MOUNT
 PART & DWG #: PSO-LBUV-T
 SHEET 1 OF 1
 SCALE: N/A
 DWG SIZE: A

MATERIAL: 316 STAINLESS STEEL
 FINISH: N/A

DATE CHANGE BY APPD BY

PURGE SOLUTIONS
 WEBSTER, TEXAS, USA
 832-388-7198

CHANGE(S) DESCRIPTION

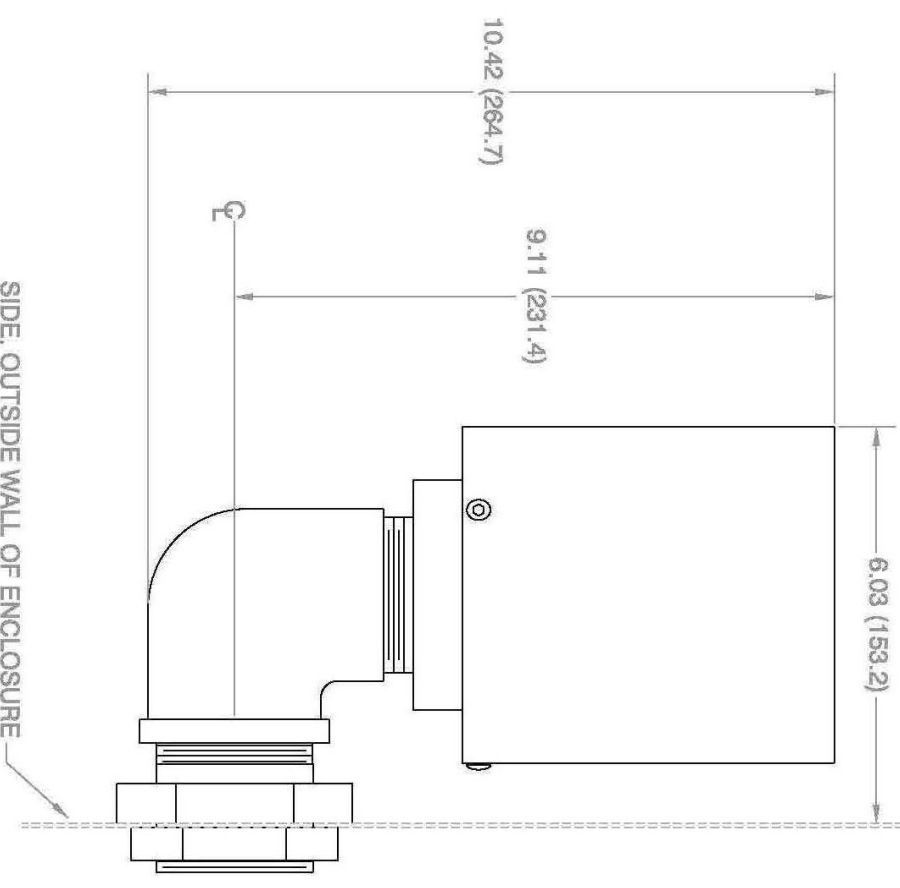

NOTES:
 1. REQUIRED HOLE THRU ENCLOSURE WALL FOR VENT IS 2.38Ø (60.5Ø)

REV #	ECO #	CHANGE(S) DESCRIPTION		DATE	CHANGE BY	APPD BY	
<p>The contents of this drawing is the sole property of Purge Solutions. This print and/or its contents shall not be traced or reproduced without prior written permission from Purge Solutions. It shall not be used directly or indirectly in any way detrimental to the interest of Purge Solutions.</p>		<p>DO NOT SCALE DRAWING UNLESS OTHERWISE SPECIFIED. Dimensions are in inches Dimensions in () are in mm Tolerances: X = ± 0.015 XX = ± 0.010 XXX = ± 0.005 Angular = ± 0.5° Break All Sharp Edges 82 ✓ Aluminum Except As Noted</p>		<p>DRAWN: W/JT DATE: 16/OCT/09</p>	<p>TITLE: LARGE BACK-UP VENT SIDE MOUNT</p>		
		<p>CHECKED: W/JT DATE: 16/OCT/09</p>	<p>PART & DWG #: PSO-LBUV-S</p>	<p>MATERIAL: 316 STAINLESS STEEL</p>			
		<p>APPROVED: W/JT DATE: 16/OCT/09</p>	<p>SHEET 1 OF 1</p>	<p>SCALE: N/A</p>	<p>DWG SIZE A</p>	<p>FINISH: N/A</p>	

Section 5

Startup Procedures

The following steps should be performed when initially starting up a Purge Solutions, Inc. Type Z Purge and Pressurization System.



WARNING: Failure to heed the following information may lead to injury of personnel and / or equipment damage.



WARNING: Applicable permits must be obtained and appropriate precautions must be taken to prevent possible injury to personnel or equipment damage when installing purge and pressurization system.



WARNING: Do not open the electrical equipment enclosure in a hazardous area even when de-energized unless area has been properly tested and is known to not contain explosive or combustible materials.



WARNING: Before initially starting the equipment, electrical power wiring must be checked for correct size and routing.



NOTE: Refer to all ATEX, CEC, IECEX, NEC, NFPA and UKEx certificates for any Special Conditions of Use. If the sign "X" is placed after the certificate number, it indicates that the equipment or protective system is subject to special conditions for safe use specified in the schedule of the certificate.



NOTE: Review all material and safety information in this manual and install in accordance with this document and all other applicable ATEX, CEC, IECEX, NEC, NFPA and UKEx standards.



NOTE: To help prevent possible damage to purge and pressurization system; minimum overpressure should always be set by increasing the pressure / flow rate through regulator, up to the desired setting.

Continuous Dilution Explosive Gas Applications Should Perform the Initial Startup Steps as Follows:

Step 1: Make sure that area surrounding panel to be purged and pressurized is non-hazardous.

Step 2: Open panel door.



WARNING: Steps 3 and 4: are necessary to keep from over pressurizing enclosure as this could damage or change factory setting of Purge Indicator pressure switch.

Step 3: Turn on protective gas supply to panel by turning Protective Gas Inlet Kit manifold valve to ON position and then a) pulling up on Small or b) pushing down on Medium and Large and then turning Pressure Regulator adjustment knob counter-clockwise to verify that Protective Gas Inlet Kit is supplying panel with protective gas.

Step 4: Turn Protective Gas Inlet Kit pressure regulator adjustment knob clockwise to stop protective gas flowing into panel; while leaving Protective Gas Inlet Kit manifold valve in the ON position.

Step 5: Close and latch enclosure door.



WARNING: Do not connect power to electrical equipment located in enclosure Purge Indicator will be monitoring minimum overpressure, unless area has been properly tested and is known not to contain explosive materials.

Step 6: Connect power to the Purge Indicator.

Step 7: Increase the flow rate of the protective gas supplying panel by rotating the Protective Gas Inlet Kit pressure regulator adjustment knob counter clockwise; until the Purge Indicator Green LED illuminates.

Step 8: Rotate pressure regulator adjustment knob one half more turn; this is needed to compensate for any fluctuations in protective gas supply.

Step 9: Lock Protective Gas Inlet Kit setting by a) pushing down on Small or b) pulling up on Medium and Large, Pressure Regulator adjustment knob **or remove pressure regulator adjustment knob to insure tamper resistance.**

Step 10: Disconnect power from the Purge Indicator.

Step 11: Turn Protective Gas Inlet Kit manifold valve to the OFF position; stopping protective gas from flowing into panel.



NOTE: *If gauge needle is between two numbers; increase gauge reading to next highest whole number as the Purge Dilution Calculator will only accept whole numbers from the Protective Gas Inlet Kit pressure gauge.*



NOTE: *Only the pressure recorded when the Protective Gas Inlet Kit shutoff valve is in the OFF position should be used to calculate the Purge Cycle Time required before power can be connected to the electronics within the purged and pressurized panel.*



NOTE: *The Purge Dilution Calculator can only be used if you are using a Purge Solutions, Inc. Protective Gas Inlet Kit, as the Purge Cycle Time calculations are based on empirical test performed with Purge Solutions, Inc. Protective Gas Inlet Kits and proprietary purge system components.*

Step 12: Record the pressure reading on the Protective Gas Inlet Kit pressure gauge; *the recorded pressure will be used to calculate the Purge Cycle Time before power can be applied to electronics within the protected pressurized panel.*

Step 13: Calculate the Purge Cycle Time, which can be performed by using our Purge Dilution Calculator located on home page of our web site www.purgesolutions.com.



NOTE: *The Purge Cycle Time for Class I, Division 2 Applications must be long enough to ensure that at least four (4) times the volume of free space in the enclosure of purge gas are exchanged before power can be connected to the electrical equipment inside the pressurized panel.*



NOTE: *The Purge Cycle Time for Group II, Zone 2 Applications must be long enough to ensure that at least five (5) times the volume of free space in the enclosure of purge gas are exchanged before power can be connected to the electrical equipment inside the pressurized panel.*



NOTE: *If motor or other rotating electrical equipment; the Purge Cycle Time must be long enough to ensure that at least ten (10) times the volume of free space in the enclosure of purge gas are exchanged before power can be connected to the pressurized electrical equipment.*



WARNING: *The number of exchanged volumes may be higher in some situations.*



NOTE: *The Purge Cycle Time can be reduced by increasing the pressure of purge gas being supplied into the enclosure. Start at Step 7 and increase the flow rate with Protective Gas Inlet Kit pressure regulator. Use the new reading on Protective Gas Inlet Kit pressure gauge to calculate a lower Purge Cycle Time, repeating until an appropriate Purge Cycle Time is reached.*

Step 13: Turn on protective gas supply to panel by turning the Protective Gas Inlet Kit manifold valve to the ON position.

Step 14: Connect power to the Purge Indicator; Green LED should illuminate.

Step 15: With Green LED illuminated; start the manual Purge Cycle Time.

Step 16: With Purge Indicator Green LED remaining steady state illuminated and Purge Cycle Time verified; power can be connected to electrical equipment within pressurized protected panel. ***Purge Cycle Time and Protective Gas Inlet Kit pressure gauge reading should be recorded for used during any future maintenance or service of the purged and pressurized panel.***



NOTE: If Purge Indicator Green LED does not remain illuminated during or after Purge Cycle, check for the following possible problems.

- Panel minimum overpressure is too low; increase protective gas flow rate at the Protective Gas Inlet Kit pressure regulator.
- Panel door is open or allowing too much leakage; increase door compression sealing, gland plate compression sealing and / or any other seals that maybe leaking on enclosure.
- Protective Gas Inlet Kit manifold valve has not been fully put in the ON position.
- Check that there is nothing restricting the exhaust vent ports from allowing unrestricted flow.



NOTE: If minimum overpressure inside panel becomes less than 0.30 inch H₂O (0.75 mbar) for gas hazardous areas, the Purge Indicator does not disconnect power from the electrical equipment within the panel it has been monitoring; it will only alarm. Locally with Purge Indicator Green LED turning off and remotely if Purge Indicator dry contact alarm has been connected.

Continuous Dilution Combustible Dust Applications Should Perform the Initial Startup Steps as Follows:



WARNING: *Purging of equipment is not suitable for Class II, Division 2 and Group III, Zone 22 Combustible Dust Areas since purging is likely to cause a dust cloud from purge gas exiting exhaust vent.*

Step 1: Make sure that area surrounding panel to be pressurized is non-hazardous.

Step 2: Open panel door.



WARNING: *Steps 3 and 4 are necessary to keep from over pressurizing enclosure; as this could damage or change factory setting of Purge Indicator pressure switch.*

Step 3: Turn on protective gas supply to panel by turning Protective Gas Inlet Kit manifold valve to ON position and then a) pulling up on Small or b) pushing down on Medium and Large and then turning Pressure Regulator adjustment knob counter-clockwise to verify that Protective Gas Inlet Kit is supplying panel with protective gas.

Step 4: Turn Protective Gas Inlet Kit pressure regulator adjustment knob clockwise to stop protective gas flowing into panel; while leaving Protective Gas Inlet Kit manifold valve in the ON position.

Step 5: Clean and remove all Combustible Dust from inside enclosure.

Step 6: Close and latch enclosure door.



WARNING: *Do not connect power to electrical equipment located in panel Purge Indicator is installed, unless area has been properly cleaned and is known not to contain combustible materials.*

Step 7: Connect power to the Purge Indicator.

Step 8: Increase the flow rate of the protective gas supplying panel by rotating the Protective Gas Inlet Kit pressure regulator adjustment knob counter clockwise until the Purge Indicator Green LED illuminates; this indicates that a minimum overpressure of 0.50 inch H₂O (1.25 mbar) for Dust Hazardous Areas is being maintained inside enclosure.

Step 9: Rotate pressure regulator adjustment knob one half more turn; this is needed to compensate for any fluctuations in protective gas supply.

Step 10: Lock minimum overpressure setting by a) pushing down on Small or b) pulling up on Medium and Large, Pressure Regulator adjustment knob **or remove pressure regulator adjustment knob to insure tamper resistance.**

Step 11: With Purge Indicator Green LED remaining illuminated; power can be connected to electrical equipment within pressurized protected panel. ***Minimum overpressure settings should be recorded for use during any future maintenance or service of pressurized panel.***



NOTE: If Purge Indicator Green LED does not remain illuminated, check for the following possible problems.

- Panel minimum overpressure is too low; increase protective gas flow rate at the Protective Gas Inlet Kit pressure regulator.
- Panel door is open or allowing too much leakage; increase door compression sealing, gland plate compression sealing and / or any other seals that maybe leaking on enclosure.
- Protective Gas Inlet Kit manifold valve has not been fully put in the ON position.
- Check that there is nothing restricting the exhaust vent ports from allowing unrestricted flow.



NOTE: If minimum overpressure inside panel becomes less than 0.5 inch H₂O (1.25 mbar) for dust hazardous areas, the Purge Indicator does not disconnect power from the electrical equipment within the panel it has been monitoring; it will only alarm. Locally with Purge Indicator Green LED turning off and remotely if Purge Indicator dry contact alarm has been connected.

Leakage Compensation Explosive Gas Applications Should Perform Initial Startup Steps as follows:



WARNING: *Purging of equipment is not suitable for Class II, Division 2 and Group III, Zone 22 Combustible Dust Areas since purging is likely to cause a dust cloud from purge gas exiting exhaust vent.*



NOTE: *For Class II, Division 2 and Group III, Zone 22 Combustible Dust Applications use Continuous Dilution Protective Gas Inlet Kit to supply panel with protective gas purging and minimum overpressure.*

Step 1: Make sure that area surrounding panel to be purged and pressurized is known to be non-hazardous.

Step 2: Open panel door.



WARNING: *Steps 3, 4, 5, 6 and 7: are necessary to keep from over pressurizing panel as this could damage or change factory setting of Purge Indicator pressure switch.*

Step 3: Turn on protective gas supply to panel by turning Protective Gas Inlet Kit manifold valve to ON position and then a) pulling up on Small or b) pushing down on Medium and Large and then turning Pressure Regulator adjustment knob counter-clockwise to verify protective gas is being supplied to panel.

Step 4: Turn Protective Gas Inlet Kit pressure regulator adjustment knob clockwise to stop protective gas flowing into panel; while leaving Protective Gas Inlet Kit manifold valve in the ON position.

Step 5: Open Protective Gas Inlet Kit leakage compensation needle valve by turning clockwise; verifying that panel is being supplied with protective gas through the Protective Gas Inlet Kit manifold leakage compensation needle valve port.

Step 6: Stop flow through needle valve port by screwing needle valve into Protective Gas Inlet Kit manifold counter-clock wise, until protective gas stops flowing through Protective Gas Inlet Kit manifold leakage compensation needle valve port.

Step 7: Turn Protective Gas Inlet Kit pressure regulator adjustment knob clockwise until protective gas flow into panel stops.

Step 8: Properly close and latch enclosure door.



WARNING: *Do not connect power to electrical equipment located in enclosure Purge Indicator will be monitoring minimum overpressure, unless area has been properly tested and is known not to contain explosive materials.*

Step 9: Connect power to the Purge Indicator.

Step 10: Turn Protective Gas Inlet Kit manifold valve to the ON position.

Step 11: Start turning Protective Gas Inlet Kit pressure regulator adjustment knob counter-clockwise; increasing purge gas flow rate to panel until Purge Indicator Green LED is illuminated.

Step 12: Rotate pressure regulator adjustment knob one half more turn counter-clockwise, which is needed to compensate for any fluctuations in protective gas supply.

Step 13: Lock Purge Gas Flow Rate setting by a) pushing down on Small or b) pulling up on Medium and Large, Pressure Regulator adjustment knob ***or remove pressure regulator adjustment knob to insure tamper resistance.***

Step 14: Turn Protective Gas Inlet Kit manifold valve to the OFF position, ***not the pressure regulator;*** this will also turn off Purge Indicator Green LED.

Step 15: Start turning Protective Gas Inlet Kit leakage compensation needle valve clockwise; increasing leakage compensation minimum overpressure to panel until Purge Indicator Green LED is illuminated.

Step 16: Rotate leakage compensation needle valve one half more turn clockwise; which is needed to compensate for any fluctuations in protective gas supply.

Step 17: Using jam nut, lock leakage compensation needle valve in place on the Protective Gas Inlet Kit manifold block to maintain leakage compensation minimum overpressure setting.

Step 18: If Purge Indicator Green LED remains illuminated; this indicates that the panel is maintaining a minimum overpressure above 0.30 inch H₂O (0.75 mbar) for gas hazardous locations

Step 19: Disconnect power from the Purge Indicator.

Step 20: Turn Protective Gas Inlet Kit manifold valve to the ON position.

Step 21: Record the pressure reading on the Protective Gas Inlet Kit pressure gauge; ***the recorded pressure will be used to calculate the Purge Cycle Time before power can be applied to electronics within the protected pressurized enclosure.***



NOTE: If gauge needle is between two numbers; increase gauge reading to next highest whole number as the Purge Dilution Calculator will only accept whole numbers from the Protective Gas Inlet Kit pressure gauge.



NOTE: Only the pressure recorded when the Protective Gas Inlet Kit manifold valve is in the OFF position should be used to calculate the Purge Cycle Time required before power can be connected to the electronics within the purged and pressurized enclosure.



NOTE: The Purge Dilution Calculator can only be used if you are using a Purge Solutions, Inc. Protective Gas Inlet Kit, as the Purge Cycle Time calculations are based on empirical test performed with Purge Solutions, Inc. Protective Gas Inlet Kits and proprietary purge system components.

Step 22: Calculate the Purge Cycle Time, which can be performed by using our Purge Dilution Calculator located on our web site www.purgesolutions.com.



NOTE: The Purge Cycle Time for Class I, Division 2 Applications must be long enough to ensure that at least four (4) times the volume of free space in the enclosure of purge gas are exchanged before power can be connected to the electrical equipment inside the pressurized panel.



NOTE: The Purge Cycle Time for Group II, Zone 2 Applications must be long enough to ensure that at least five (5) times the volume of free space in the enclosure of purge gas are exchanged before power can be connected to the electrical equipment inside the pressurized panel.



NOTE: If motor or other rotating electrical equipment; the Purge Cycle Time must be long enough to ensure that at least ten (10) times the volume of free space in the enclosure of purge gas are exchanged before power can be connected to the pressurized electrical equipment.



WARNING: The number of exchanged volumes may be higher in some situations.



NOTE: The Purge Cycle Time can be reduced by increasing the pressure of purge gas being supplied into the enclosure. Start at Step 7 and increase the flow rate with Protective Gas Inlet Kit pressure regulator. Use the new reading on Protective Gas Inlet Kit pressure gauge to calculate a lower Purge Cycle Time, repeating until an appropriate Purge Cycle Time is reached.

Step 23: Connect power from the Purge Indicator; Green LED should illuminate.

Step 24: With Green LED illuminated; start the manual Purge Cycle Time.

Step 25: With Purge Cycle Time verified and Purge Indicator Green LED remaining steady state illuminated; power can be connected to electrical equipment within pressurized protected panel. **Purge Cycle Time and Flow Rate settings should be recorded for use during any future maintenance or service of purged and pressurized panel.**



NOTE: If Purge Indicator Green LED does not remain illuminated, check for the following possible problems.

- Panel minimum overpressure is too low; increase protective gas flow rate at the Protective Gas Inlet Kit pressure regulator.
- Panel door is open or allowing too much leakage; increase door compression sealing, gland plate compression sealing and / or any other seals that maybe leaking on enclosure.
- Protective Gas Inlet Kit manifold Protective Gas Supply valve has not been fully put in the ON position.
- Check that there is nothing restricting the exhaust vent ports from allowing unrestricted flow.



NOTE: If minimum overpressure inside panel becomes less than 0.30 inch H₂O (0.75 mbar) for gas hazardous areas, the Purge Indicator does not disconnect power from the electrical equipment within the panel it has been monitoring; it will only alarm. Locally with Purge Indicator Green LED turning off and remotely if Purge Indicator dry contact alarm has been connected.

Section 6

Maintenance or Service



WARNING: Failure to heed the following information may lead to injury of personnel or equipment damage.



WARNING: Applicable permits must be obtained and appropriate precautions must be taken to prevent possible injury to personnel or equipment damage when installing purge and pressurization system.



CAUTION: Do not open the electrical equipment enclosure in a hazardous location even when de-energized unless area has been properly tested and is known to not contain explosive or combustible materials.



CAUTION: Electrical equipment components may be hot even when power is not applied. Take appropriate precautions to prevent injury from contact with hot items.

Continuous Dilution Explosive Gas Application Maintenance Shutdown and Startup Procedure:

Step 1: Properly disconnect power from all pressurized panel electronics, which requires maintenance or servicing.

Step 2: Turn Protective Gas Inlet Kit manifold valve to the OFF position. **Not at the Protective Gas Inlet Kit pressure regulator. The pressure regulator setting should remain the same to keep the purge gas CFM (LPM) flow rate the same as what was established during the initial Purge Cycle Time set up.**



WARNING: Do not open the electrical equipment panel in a hazardous location even when de-energized unless area has been properly tested and is known to not contain explosive materials.



CAUTION: Electrical equipment components may be hot even when power is not applied. Take appropriate precautions to prevent injury from contact with hot items.

Step 3: Enclosure door may now be opened for maintenance or service can begin.

Step 4: After maintenance or servicing is completed; properly close and seal enclosure door.

Step 5: Supply purge gas to panel by turning the Protective Gas Inlet Kit manifold valve to the ON position. ***The Protective Gas Inlet Kit pressure regulator should remain the same to keep the purge gas CFM (LPM) flow rate the same as what was established during the initial Purge Cycle Time set up.***



WARNING: Do not connect power to electrical equipment located in panel Purge Indicator is installed, unless area has been properly tested and is known not to contain explosive materials.

Step 6: Connect power to Purge Indicator; Green LED should illuminate.

Step 7: With Purge Indicator Green LED illuminated; start manual purge cycle.



NOTE: The Purge Cycle Time and Purge Gas Inlet Kit regulator pressure setting should remain the same as what was established during the initial Purge Cycle Time startup.

Step 8: After the manual Purge Cycle Time is completed and Green LED is still illuminated; this indicates that the enclosure is maintaining a minimum overpressure above 0.30 inch H₂O (0.75 mbar) for gas hazardous locations.

Step 9: With Purge Indicator Green LED remaining illuminated; power can be connected to the electrical equipment in the pressurized protected electronics enclosure.



NOTE: If Purge Indicator Green LED does not remain illuminated during or after Purge Cycle, check for the following possible problems.

- Protective gas supply flow rate is too low; increase protective gas flow rate supplying Protective Gas Inlet Kit and / or Protective Gas Inlet Kit pressure regulator.
- Panel door is open or allowing too much leakage; increase door compression sealing, gland plate compression sealing and / or any other seals that maybe leaking on enclosure.
- Protective Gas Inlet Kit manifold valve has not been fully put in the ON position.
- Check that there is nothing restricting the exhaust vent ports from allowing unrestricted flow.



NOTE: If minimum overpressure inside panel becomes less than 0.30 inch H₂O (0.75 mbar) for gas hazardous locations, the Purge Indicator does not disconnect power from the electrical equipment within the panel it has been monitoring; it will only alarm. Locally with Purge Indicator Green LED turning off and remotely if Purge Indicator dry contact alarm has been connected.

Continuous Dilution Combustible Dust Applications Maintenance Shutdown and Startup Procedure:



WARNING: *Purging of equipment is not suitable for Class II, Division 2 and Group III, Zone 22 Combustible Dust Areas since purging is likely to cause a dust cloud from purge gas exiting exhaust vent.*

Step 1: Properly disconnect power from all pressurized panel electronics, which requires maintenance or service.

Step 2: Turn Protective Gas Inlet Kit manifold Protective Gas Supply valve to the OFF position. **Not at the Protective Gas Inlet Kit pressure regulator. The pressure regulator setting should remain the same to keep the same protective gas minimum overpressure as was established during the initial set up.**



CAUTION: *Do not open the electrical equipment panel in a hazardous location even when de-energized unless area has been properly cleaned and is known to not contain combustible materials.*



CAUTION: *Electrical equipment components may be hot even when power is not applied. Take appropriate precautions to prevent injury from contact with hot items.*

Step 3: Enclosure door may now be opened for maintenance or service to begin.

Step 4: Clean and remove all Combustible Dust from inside enclosure.

Step 5: Properly close and seal enclosure door.

Step 6: Supply purge gas to panel by turning the Protective Gas Inlet Kit manifold valve to the ON position. **The Protective Gas Inlet Kit pressure regulator should remain the same to keep the protective gas minimum overpressure the same as what was established during the initial set up.**



WARNING: *For Combustible Dust application do not connect power to electrical equipment located in panel Purge Indicator is installed, until combustible dust accumulations within enclosure have been removed.*

Step 7: Connect power to the Purge Indicator; this should illuminate Green LED, which indicates 0.50 inch H₂O (1.25 mbar) for dust hazardous areas is being maintained in panel.

Step 8: With Purge Indicator Green LED illuminated; power can be connected to electronics in pressurized protected panel.



NOTE: If Purge Indicator Green LED does not remain illuminated, check for the following possible problems.

- Panel minimum overpressure is too low; increase protective gas flow rate at the Protective Gas Inlet Kit pressure regulator.
- Panel door is open or allowing too much leakage; increase door compression sealing, gland plate compression sealing and / or any other seals that maybe leaking on enclosure.
- Protective Gas Inlet Kit manifold valve has not been fully put in the ON position.
- Check that there is nothing restricting the exhaust vent ports from allowing unrestricted flow.



NOTE: If minimum overpressure inside panel becomes less than 0.50 inch H₂O (1.25 mbar) for dust hazardous areas, the Purge Indicator does not disconnect power from the electrical equipment within the panel it has been monitoring; it will only alarm. Locally with Purge Indicator Green LED turning off and remotely if Purge Indicator dry contact alarm has been connected.

Leakage Compensation Explosive Gas Applications Maintenance Shutdown and Startup Procedure:



WARNING: *Purging of equipment is not suitable for Class II, Division 2 and Group III, Zone 22 Combustible Dust Areas since purging is likely to cause a dust cloud from purge gas exiting exhaust vent.*

Step 1: Properly disconnect power from all pressurized panel electronics, which requires maintenance or service.

Step 2: Turn Protective Gas Inlet Kit manifold valve to the OFF position. **Do not change settings at the Protective Gas Inlet Kit pressure regulator or leakage compensation needle valve. The Protective Gas Inlet Kit pressure regulator and leakage compensation needle valve settings should remain the same to keep the purge gas CFM (LPM) flow rate and minimum overpressure the same as what was established during the initial set up.**



CAUTION: *Do not open the electrical equipment enclosure in a hazardous location even when de-energized unless area has been properly tested and is known to not contain explosive materials.*



CAUTION: *Electrical equipment components may be hot even when power is not applied. Take appropriate precautions to prevent injury from contact with hot items.*

Step 3: Enclosure door may now be opened for maintenance or service to begin.

Step 4: After maintenance or servicing have been completed, properly close and seal enclosure door.

Step 5: Turn Protective Gas Inlet Kit manifold valve to the ON position.



WARNING: *Do not connect power to electrical equipment located in panel Purge Indicator is installed, unless area has been properly tested and is known not to contain explosive materials.*

Step 6: Connect power to Purge Indicator; Purge Indicator Green LED should illuminate, which indicates that manual Purge Cycle can start.



NOTE: *The Purge Cycle Time and Purge Gas Inlet Kit regulator pressure setting should remain the same as what was established during initial Purge Cycle Time startup.*

Step 7: When purge cycle is completed; turn Protective Gas Inlet Kit manifold valve to the OFF position; enclosure is now being supplied protective gas through the Protective Gas Inlet Kit leakage compensation needle valve port.

Step 8: With Purge Indicator green LED remaining illuminated; this indicates that the enclosure is maintaining a minimum overpressure above 0.30 inch H₂O (0.75 mbar) for gas hazardous locations.

Step 9: With enclosure maintaining a minimum overpressure above 0.30 inch H₂O (0.75 mbar) for gas hazardous locations; power can now be connected to electronics in pressurized protected panel.



NOTE: *If Purge Indicator Green LED does not remain illuminated during or after Purge Cycle, check for the following possible problems.*

- *Protective gas supply flow rate is too low; increase protective gas flow rate supplying Protective Gas Inlet Kit and / or Protective Gas Inlet Kit pressure regulator.*
- *Panel door is open or allowing too much leakage; increase door compression sealing, gland plate compression sealing and / or any other seals that maybe leaking on enclosure.*
- *Protective Gas Inlet Kit manifold valve has not been fully put in the ON position.*
- *Check that there is nothing restricting the exhaust vent ports from allowing unrestricted flow.*



NOTE: *If minimum overpressure inside panel becomes less than 0.30 inch H₂O (0.75 mbar) for gas hazardous locations, the Purge Indicator does not disconnect power from the electrical equipment within the panel it has been monitoring; it will only alarm. Locally with Purge Indicator Green LED turning off and remotely if Purge Indicator dry contact alarm has been connected.*

Section 7

Options

External Exhaust Vent Kits:

For applications that the protective gas should not be vented in the area surrounding the purge / pressurized enclosure and taken to a manifold or outside through a wall; Purge Solutions, Inc. offers External Exhaust Vent Kits, which include Exhaust Vent, Housing Cover and Fitting. This option allow the Purge Unit to measure the flow through the exhaust vent during the purge cycle and monitoring the minimum overpressure during pressurization; while taking the protective gas out of the purge and pressurized enclosure area. Contact Purge Solutions, Inc. to discuss custom increased safety enclosure requirements.

Increased Safety Enclosures:

Purge Solutions, Inc. also offers ATEX, IECEx, NEMA and UKEx Increased Safety Enclosures that are available in over 60 standard sizes or we can custom built to the customer specifications, including all holes and cutouts for cable glands, widows, purge systems and any other component can be incorporated into fabrication. As long as the design stays within our conditions of certification no additional assessment and testing is required to maintain ATEX, IECEx, NEMA and UKEx certification.

Our proprietary hinge design allows clamping of door on all four sides for maximum ingress protection with incorporated fasteners that allows door to be removed as needed. Enclosures can be fabricated from 304 or 316 stainless steel, powder coated carbon steel or aluminum with all seams continuously welded and ground before finish is applied; having an IP66 / NEMA 4 / NEMA 4X ingress protection rating and an ambient temperature rating of -40°F to 176°F (-40°C to 80°C). Contact Purge Solutions, Inc. to discuss custom increased safety enclosure requirements.

Increased Safety Window Kits:

For increased safety enclosure that require viewing of components mounted within the enclosure Purge Solutions, Inc. offers both opening and non-opening Increased Safety Window Kits in ten (10) standard window viewing sizes. All have an IP66 / NEMA 4 / NEMA 4X ingress protection rating and an ambient temperature rating of -40°F to 176°F (-40°C to 80°C).

If there is not a viewing opening listed in our standard sizes that meets your application requirements; Purge Solutions, Inc. can custom build an opening or non-opening Increased Safety Window Kit for you. As long as the design stays within our conditions of certification no additional assessment and testing is required to maintain ATEX, IECEx, NEMA and UKEx certification, ingress protection rating and ambient temperature rating. Contact Purge Solutions, Inc. to discuss custom increased safety window requirements.

Vortex Cabinet Cooler Systems:

For applications where thermal management of electrical cabinets and control panels are required; Purge Solutions, Inc. offers Vortex Cabinet Cooler Systems, which provide cooling capacities for your application and maintain a NEMA 4X (IP66) rating for installation and use in hazardous locations.

The Vortex Cabinet Cooler Systems can be a stand-alone cooling system or be used in combination with one of our Type X, Y or Z – Purge Systems. For help in selecting a Vortex Cabinet Cooler System for your application and / or combining it with a purge and pressurization system contact Purge Solutions, Inc.



NOTE: There are special modifications and sizing requirements to be made before Vortex Cabinet Coolers are able to be installed and used in a hazardous location.

Environmental Pressurization Kits:

Purge Solutions, Inc. also offers an all stainless steel Environmental Pressurization Kit, which are used to pressurize an enclosure in a non-hazardous location. The pressurization keeps any gases, vapors, dust or fibers from ingressing into the enclosure and damaging its contents.

Environmental Pressurization Kits can be mounted on the side, top or bottom of an enclosure. Model number PSO-EPK-L is our left side mount version, model number PSO-EPK-R is our right side mount version, model number PSO-EPK-T is our top mount version and model number PSO-EPK-B is our bottom mount version.

Each Differential Gauge Purge Kit comes complete with differential pressure gauge, pressurization gas inlet kit, exhaust vent, all mounting hardware, fittings and fasteners.

Differential Pressure Gauge Kits:

Purge Solutions, Inc. also offers an all stainless steel Differential Pressure Gauge Kit, which can be mounted on the side, top or bottom of an enclosure. Model number PSO-DPG-L is our left side mount version, model number PSO-DPG-R is our right side mount version, model number PSO-DPG-T is our top mount version and model number PSO-DPG-B is our bottom mount version.

Section 8

Getting Help

Getting Help:

Answers to many questions concerning the Type Z – Purge and Pressurization Systems or any of our other products we offer can be found in this manual. If a problem or question is encountered that is not covered in the documentation provided, assistance is available Monday through Friday (except holidays), from 8 a.m. to 5 p.m. United States central time. To obtain assistance, please call Purge Solutions, Inc. at **832-368-7166**.

For assistance during times other than normal business hours, consult our World Wide Web Internet site at **<http://www.purgesolutions.com>**. This site includes equipment information, news releases, and other information. E-mail can be sent to **info@purgesolutions.com**.
